

RENAULT

AE 380 .19 TD MAGNUM

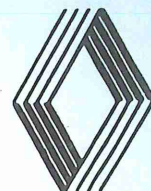

UNITED KINGDOM AND IRELAND	TRACTOR	DESIGN	UK PLATED
	GCW	59,000kg	38,000kg
	GVW	18,000kg	17,000kg
	FRONT AXLE	7,100kg	7,100kg
	REAR AXLE	11,500kg	10,500kg



INTEGRAL CAB CONCEPT

THE NEW EUROPEAN STANDARD IN INTERIOR SPACE, COMFORT AND SECURITY

CAB STRUCTURE – A modular concept

The lower module encapsulating the power unit and driveline with separate 71° tilt cab accommodation above.

INTEGRAL SPACE – A new dimension in space – 8.9 cubic metres in cab module

Interior height of 1.87 metres (over 6 feet) throughout.

Completely flat floor providing exceptional on-board mobility.

Sofa-bed 1,900mm x 750mm x 100mm comfort for sitting in addition to sleeping.

Storage space totalling an impressive 1,000 litres capacity.

3 deep, easily accessible, floor level storage lockers, under sofa-bed.

2 full length AIRCRAFT STYLE lockers.

Shelving above the windscreen with provision for TV fitment.

2 built-in wardrobes with floor level shoe lockers.

Flask holder in the central console.

INTEGRAL COMFORT – Low frequency, four point cab air suspension.

Extensive thermal and sound insulation combined with easily cleaned, relaxing shade, interior trim.

ETM (Electronic Temperature Management) heating, ventilation & air-conditioning system with digital temperature set/display.

ERGOVISION instrument panel containing ergonomically positioned controls, switches, warning devices and instrumentation.

COMMANDSEAT driver's & passenger's seat with air assisted controls for seat adjustment & fore/aft isolation.

Adjustable headrests. Passenger seat armrests.

Steering wheel fully adjustable for height and rake.

Radio pre-equipment including speakers and aerial.

Electrically operated door windows. Multi-position, roller action sun blinds. Electrically operated on passenger side and windscreen, manually operated on the driver's side.

Full 180° curtaining provided by the sun blinds in their lowest position.

Diffused lighting from four symmetrically positioned interior lamps.

Adjustable shaving/vanity mirror.

INTEGRAL SECURITY

– Active safety

Exceptional visibility from the 4.2 square metres of tinted glass.

Commanding view from the elevated driving position.

4 halogen headlamps with in-cab levelling device. 2 long range driving lamps & 2 front fog lamps.

Heated, electrically adjustable rear view mirrors.

Cab entry/exit – wide, in-line, non-slip and illuminated steps located behind the front axle.

Large doors – 1,500mm x 900mm.

The cross cab access allows comfortable kerb side entry/egress, access to the standard catwalk is achieved directly from the driving position.

– Passive safety

Driving position rearward of the front axle and wheels

Cab module complies with European norms on impact resistance (ECE No. 29)

INTEGRAL AERODYNAMICS

Air flow optimised by cab design to integrate with maximum height semi-trailers.

Smooth rounded lines for both cab and power unit modules. Integrated roof air deflector.

Fully integrated front bumper and air dam. Integrated lateral air deflectors.

INTEGRAL ANTI-CORROSION PROTECTION

All steel cab structure protected entirely with an extensive cathaphoretic paint treatment.

Box sections are additionally treated by high pressure wax injection.

An iron-zinc and PVC coated steel is used for the most exposed areas.

Damage and corrosion resistant plastics are used extensively for the power unit and cab modules.

INTEGRAL CAB INTERIOR APPOINTMENTS

Standard equipment includes the following:-

ETM heating and air conditioning

Automatic electronic tachograph KIENZLE 13.18.27

Electronic speedometer and tachometer

Gauges for:

*Turbo boost pressure

*Engine oil level and oil pressure

*Coolant level

*Air pressure

*Coolant temperature

Malfunction and daily check indicators

Centrally located emergency/stop monitor

3 speed windscreen wipers with intermittent wipe

Electric windows in driver's and passenger's door

Heated and electrically adjustable rear view mirrors

Clock

Magnum package

ENGINE
(type MIDR 06.35.40H)

Turbocharged Intercooled Diesel
 Bore: 135mm – Stroke: 140mm
 Power: (1) 275 kW (374 bhp) at 1900 rpm
 Oil capacity including filter: 27 litres
 Cooling system capacity: 50 litres
 Air compressor
 Cooling fan: Thermostatically controlled
 (1) Maximum nett output to EEC 88/195

6 cylinders in line – 4 stroke – Direct injection
 Displacement: 12.0 litres
 Torque: (1) 1650 Nm (1217 lbf.ft) at 1200 rpm
 Oil filter: With 2 replaceable cartridges
 Antifreeze: -25°C
 Pre-heating equipment
 Engine speed regulator

CLUTCH type 430DTP31000
 Single dry plate, 430mm diameter
 Air assisted hydraulic actuation
 Automatic adjustment

GEARBOX type RENAULT B18
 Compact gearbox with 3 countershafts in triangular formation. Epicyclic range gears, front splitter. Gearbox control type Range R. Lubrication by high pressure pump with replaceable cartridge oil filter. 18 forward gears (16 synchromesh + 2 crawler) and 2 reverse speeds.
 Gearbox ratios:

	Cr	1st	2nd	3rd	4th	5th	6th	7th	8th	Rev
Lo	11.09	7.36	5.12	3.71	2.78	1.98	1.38	1.00	0.75	11.05
Hi	9.55	6.34	4.41	3.20	2.40	1.71	1.19	0.86	0.65	9.51

REAR AXLE type P1345
 Hub reduction 2.26:1 Hypoid with differential lock
 Available ratios:
 19 x 37 – Ratio 4.401:1
 17 x 35 – Ratio 4.653:1

WHEELS AND TYRES
 Disc wheels: 22.5 x 9.00-10-162M22
 10 stud spigot mounted
 Front wheel nut covers
 295/80R 22.5 tyres dual rear

PERFORMANCE
 with 295/80R 22.5 tyres

	Rear axle P1345	
CODE	56458	56446
RATIO	4.653:1	4.401:1
In CRAWLER gear		
Max grade at 38.0t	42.0%	39.6%
Max speed at 190 0rpm	4.4	4.6
In TOP gear		
Max speed at 190 0rpm	75.6	80.0
Max grade	1.1%	0.9%
Max theoretical speed(2)	73.3	72.4

(2) Theoretical with 9.0m² frontal area. Limited to 115kph (72mph) by electronic road speed limiter

CHASSIS FRAME
 Side member section – 288 x 85 x 6mm
 Front bumper with integrated towing pin.
 Tool box

FRONT AXLE type E81

SUSPENSION
Front:
 Parabolic leaf springs
 Hydraulic telescopic shock absorbers
 Anti-roll bar

Rear:
 4 Parabolic leaf springs
 Hydraulic telescopic shock absorbers
 Anti-roll bar

STEERING
 Hydraulic integral power assistance
 Steering column lock

BRAKING SYSTEM
 Full air dual circuit
 Non-asbestos brake linings
Front: Full air ventilated disc brakes.
 Automatic adjustment with pad replacement warning.

Rears: Full air drum brakes.
 175 x 414 x 19mm Automatic slack adjusters.
 Load sensing valve

Parking Brake:
 Air operated spring brake chambers on rear axle.

Emergency brake:
 Dual circuit service brakes provide braking in the event of failure in the system.

Trailer brakes:
 2 line EEC system with self sealing couplings.
 Total brake lining area: 3,512cm²
 Single element brake air dryer.
 Air operated engine exhaust brake.

ELECTRICAL EQUIPMENT
 24 Volts – 2 x 12 volt 165 Ah low maintenance batteries
 Alternator – 65 Amp output with separate regulator
 Battery isolation switch

FUEL TANK
 Total capacity 800 litre, twin 400 litre tanks mounted on both sides of the vehicle.
 Lockable fuel filler caps
 Fuel heater mounted in fuel filter

STANDARD EQUIPMENT

MAGNUM package consisting of:-
 * 12 volt power outlet in cab
 * Independent cab night heater
 * Electrically operated cab tilt
 * Second bunk
 * Refrigerator
 * Central door locking with remote control
 * Side fairings
 * Front axle wheel trims

Hydraulic jack and tool kit
 Electronic speed limiter
 High level air intake
 Rear wings with spray suppression
 Air and electrical connections
 Coupling lamp doubles as work lamp with cab tilted. Catwalk 5th wheel mounting plate temporarily positioned
 Storage locker on technical module cab step

OPTIONAL EQUIPMENT**GEARBOX**

- * Power take off air operated
 -PM101: splined output shaft
 -PM102: flanged output
 Maximum torque 600Nm,
 ratio 1:1 or 1.16:1
 Rotation: opposite to engine
- * Power take off air operated
 -PM152: flanged output
 Maximum torque 400Nm,
 ratio 1.45:1 or 1.68:1
 Rotation: same as engine

WHEELS AND TYRES

- * Aluminium wheels
- * Alternative tyre sizes and sections
- * Spare wheel and tyre supplied loose

REAR SUSPENSION

- * Rear AIRTRONIC 2 bag air suspension. Height adjustment by remote control. Variation +80mm to -100mm in 20secs.

BRAKING SYSTEM

- * Anti-lock system

FUEL SYSTEM

- * Aluminium tanks

CAB

- * ~~COMMAN~~ CLUB driver's seat
- * ~~COMMAN~~ CLUB passenger seat
- * Seat belts
- * Tinted sun roof with blind

Dimensions, characteristics and data are for guidance only. We strongly recommend that vehicles be measured and weighed before any bodybuilding work commences. For further guidance please contact the Marketing Department at Dunstable. It is our continual policy to seek to improve our products, thus the right is reserved to introduce changes at any times without prior notice.

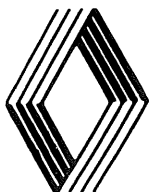

RENAULT TRUCK INDUSTRIES LIMITED

BOSCOMBE ROAD, DUNSTABLE, BEDS. LU5 4LX
 TEL 0582-471122 FAX 0582-471469

RENAULT
 Trucks

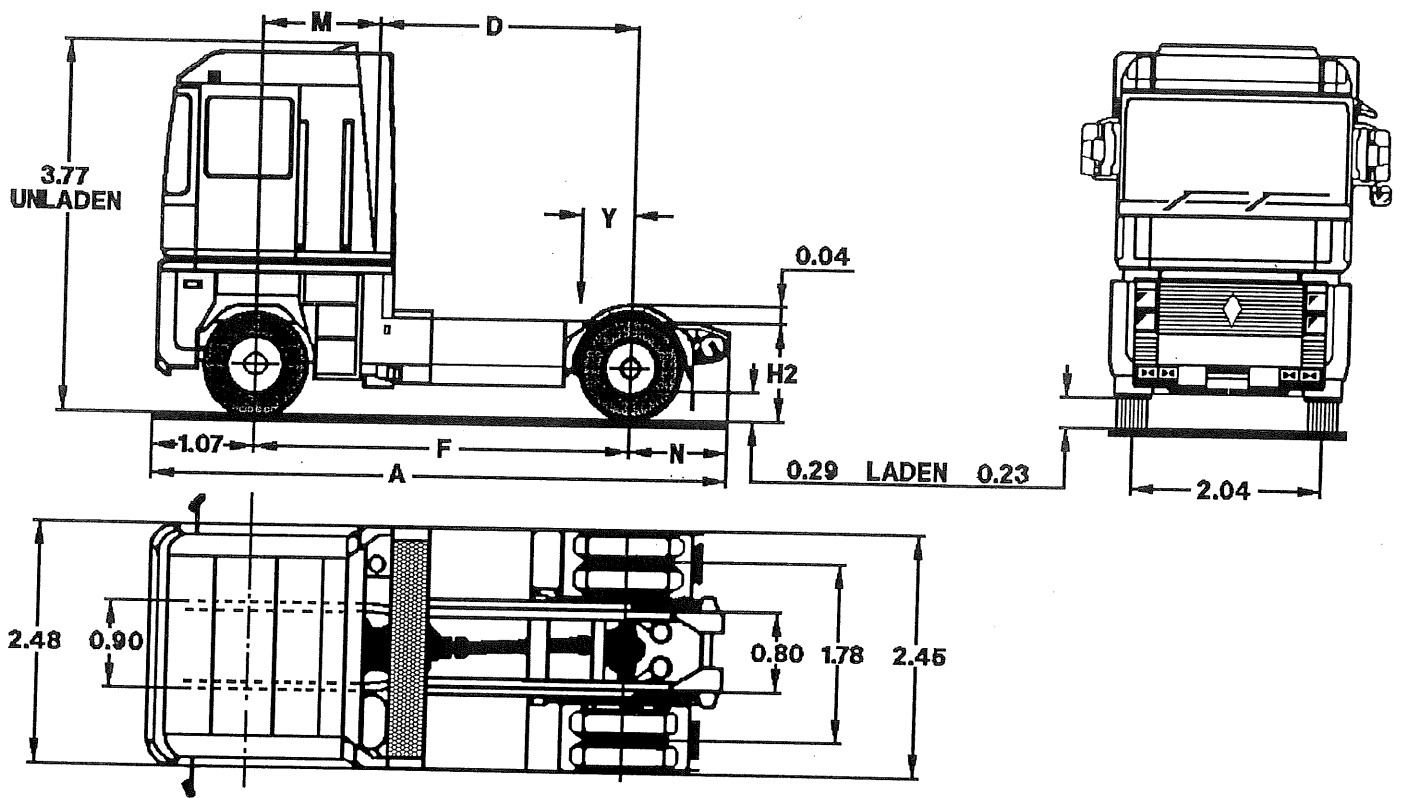

	Wheelbase	39	41	
	Cab type	INTEGRAL		
WEIGHTS (kg)		Tractor		
	Trailer Payload - 38.0t	31244	31229	
	Chassis Cab (1)	6756	6771	
	Distribution	Front	4420	4477
		Rear	2336	2294

DIMENSIONS (mm)	A	5960	6180	
	F	3900	4120	
	H2	Unladen	Mechanical Susp. 1060	Air Suspension 980
		Laden	Mechanical Susp. 950	Air Suspension 960
	M	1360	1360	
	N	990	990	
	D	2540	2760	
	Y	Minimum	470	690
		Turning Circle	Kerb to kerb	13550
			Swept	14400