

Model code : UKM_10XC036STPUS
Print date: 06/05/2022
Last updated: 06/05/2022

Prepared for :

T HIGH T6X2 PUSHER 13L E6 - GVW 23.4 T / GTW 44 T

RENAULT TRUCKS

T HIGH 520



WEIGHTS

Wheelbase		mm	3.900
Maximum Weight (registered)	Total (GVW)	Kg	23400
Payload	(C)	Kg	14843
Maximum Weight (registered)	Front axle 1	Kg	8000.00
	rear axle 1	Kg	7500
	rear axle 2	Kg	11500
Min. weight complete vehicle unladen Kerb Weight	Front axle(s)	Kg	7133.00
	total	Kg	8557
Chassis cab kerb weight	Front Axle 1	Kg	5487.00
	Rear Axle 1	Kg	1212.00
	Rear Axle 2	Kg	1858.00
	Front axles (Liftable axle down)	Kg	5487
	Rear axles (Liftable axle down)	Kg	3070
	Front axles (Liftable axle up)	Kg	5824.00
Total vehicle weight under full load at YMIN	Rear axles (Liftable axle up)	Kg	2658.00
	Front axle(s)	Kg	
Total vehicle weight under full load at YMAX	Rear axle(s)	Kg	
	Front axle(s)	Kg	
	Rear axle(s)	Kg	

This table includes the weights of the RENAULT TRUCKS options: full urea tank, oil, screen wash fluid and coolant at 100%, fuel fill level 90% and driver present (75 kg)



To maintain the driving comfort (lightness of steering, braking) of vehicles in all load and driving conditions once the vehicle is bodied, the following minimum axle load(s) must be respected: A value corresponding to 26% of the weight of the unladen bodied vehicle kerb weight (with driver, without passenger)

LENGTHS

Wheelbase		mm	3.900
Front Overhang	(H / BEP L016)	mm	1365
Wheelbase	(F / BEP L011)	mm	3900
Axle Spacing	Axle 2-3 (BEP L012.2)	mm	1325.00
Rear overhang	Chassis	mm	1046
Centre of Gravity of vehicle	at X (BEP L044)	mm	1222.00
Technical wheelbase	(F' / BEP L015)	mm	3377
Overall Chassis Length	(A / BEP L001)	mm	6311

HEIGHTS

Wheelbase		mm	3.900
Ground clearance, laden	Front (U1 / BEP H015)	mm	223
	Rear (U3 / BEP H016)	mm	215
Max. exterior height unladen	(BEP H001)	mm	3967
Max. exterior height, cab tilted, unladen	(O1 / BEP H061)	mm	4570.00
Cab height (unladen)	(O)	mm	3878
Distance from ground to lowest point at front of vehicle	Unladen (H0 / BEP H18)	mm	346.00
	Laden (H0 / BEP H18)	mm	277.00
Frame top height at front axle	Unladen (H1 / BEP H035)	mm	988.00
	Laden (H1 / BEP H036)	mm	931.00
Frame top height at drive axle	Unladen (H2 / BEP H037)	mm	973
	Laden (H2 / BEP H038)	mm	952
Frame top height at the rear of the frame	Unladen (HN)	mm	969.00
	Laden (HN)	mm	957.00
Centre of Gravity of vehicle	Unladen at Z (BEP H044)	mm	925.00
Side member height	(BEP H032)	mm	300.00

TOWING DEVICE

Wheelbase		mm	3.900
Distance between the front of the vehicle and the centre of the trailer coupling device	(BEP L073 + L016)	mm	4715.00
Distance between centre of last axle to centre of coupling device		mm	
Fifth wheel height, from top of side member	(BEP H074 + H071)	mm	270.00
Fifth wheel height from ground	Unladen (BEP H076)	mm	1245
	Laden (BEP H078)	mm	1219
Swept Swing Clearance	(BEP L078)	mm	
Fifth wheel position	Max. (Ymax / BEP L075)	mm	1100
Gross Vehicle Weight	at YMAX	Kg	23400.00
Gross Vehicle Weight, load on front axle(s)	at YMAX	Kg	8000.00
Gross Vehicle Weight, load on rear axle(s)	at YMAX	Kg	15400.00
King Pin Load	at YMAX	Kg	14843.00
King Pin Load on Front Axle(s)	at YMAX	Kg	2513.00
King Pin Load on RearAxle(s)	at YMAX	Kg	12330.00
Fifth wheel position	Min. (Ymin / BEP L077)	mm	550
Gross Vehicle Weight	at YMIN	Kg	23400.00
Gross Vehicle Weight, load on front axle(s)	at YMIN	Kg	4400.00
Gross Vehicle Weight, load on rear axle(s)	at YMIN	Kg	19000.00
King Pin Load	at YMIN	Kg	14843.00
King Pin Load on Front Axle(s)	at YMIN	Kg	-1087.00
King Pin Load on RearAxle(s)	at YMIN	Kg	15930.00

Fifth wheel position	Manufacturer's recommendation (Y / BEP L076)	mm	550
Gross Vehicle Weight	in fifth wheel position recommended by manufacturer	Kg	23400.00
Gross Vehicle Weight, load on front axle(s)	in fifth wheel position recommended by manufacturer	Kg	7904.00
Gross Vehicle Weight, load on rear axle(s)	in fifth wheel position recommended by manufacturer	Kg	15496.00
King Pin Load	in fifth wheel position recommended by manufacturer	Kg	14843.00
King Pin Load on Front Axle(s)	in fifth wheel position recommended by manufacturer	Kg	2417.00
King Pin Load on RearAxle(s)	in fifth wheel position recommended by manufacturer	Kg	12426.00
Fifth wheel position	Intermediate 1	mm	500.00
Gross Vehicle Weight	in intermediate fifth wheel position 1	Kg	23400.00
Gross Vehicle Weight, load on front axle(s)	in intermediate fifth wheel position 1	Kg	7685.00
Gross Vehicle Weight, load on rear axle(s)	in intermediate fifth wheel position 1	Kg	15715.00
King Pin Load	in intermediate fifth wheel position 1	Kg	14843.00
King Pin Load on Front Axle(s)	in intermediate fifth wheel position 1	Kg	2198.00
King Pin Load on RearAxle(s)	in intermediate fifth wheel position 1	Kg	12645.00
Fifth wheel position	Intermediate 2	mm	450.00
Gross Vehicle Weight	in intermediate fifth wheel position 2	Kg	23400.00
Gross Vehicle Weight, load on front axle(s)	in intermediate fifth wheel position 2	Kg	7465.00
Gross Vehicle Weight, load on rear axle(s)	in intermediate fifth wheel position 2	Kg	15935.00
King Pin Load	in intermediate fifth wheel position 2	Kg	14843.00
King Pin Load on Front Axle(s)	in intermediate fifth wheel position 2	Kg	1978.00
King Pin Load on RearAxle(s)	in intermediate fifth wheel position 2	Kg	12865.00
Sliding fifth wheel	front fork	mm	4.71
	rear yoke	mm	4.22

WIDTHS

Wheelbase		mm	3.900
Max exterior cab width with rear view mirrors open	(BEP W001)	mm	2960.00
Max. cab width	(BEP W002)	mm	2534
Frame width	Front (BEP W035)	mm	1080
	Rear (BEP W036)	mm	850
Width at rear wheels	Rear axle 1 (V3 / BEP W003.2)	mm	2490
	Rear axle 2 (V5 / BEP W003.3)	mm	2518.00
Track	Front (V1 / BEP W013.1)	mm	2109
	Rear 1 (V2 / BEP W013.2)	mm	2104
	Rear 2 (V4 / BEP W013.2)	mm	1854.00

OTHER

Wheelbase		mm	3.900
Approach angle	(BEP H010)	°	10
Ramp angle	(BEP H012)	°	19.90
Departure angle	(BEP H011)	°	17.90
Side member thickness	(BEP W034)	mm	7.00
Turning Radius	Overall (BEP W012)	mm	6900.00
	kerb to kerb	mm	6243.00
	interior	mm	2633.00

DTI 13 ENGINE

Max. power: 382 kW from 1430 to 1800 rpm

Max. torque: 2550 Nm from 1000 rpm to 1430 rpm

Power output (UK): 512 hp

6-cylinder in-line diesel engine - Common rail high-pressure fuel-injection (2000 bar) - 24 valves - overhead camshaft, rear-mounted timing

High pressure provided by three pumps on injector bodies.

Bore 131 mm - stroke 158 mm - Capacity 12.8 L

Electronically-controlled fan

Turbocharger

Direction of rotation (seen from gearbox end): anti-clockwise

Oil filter with additive

Intervalle vidange huile jusqu'à 100 000 km

EEC EURO VI pollution control level

Compact after-treatment system (catalytic converter, DPF, SCR)

Cooling liquid

Automatic regeneration of particulate filter



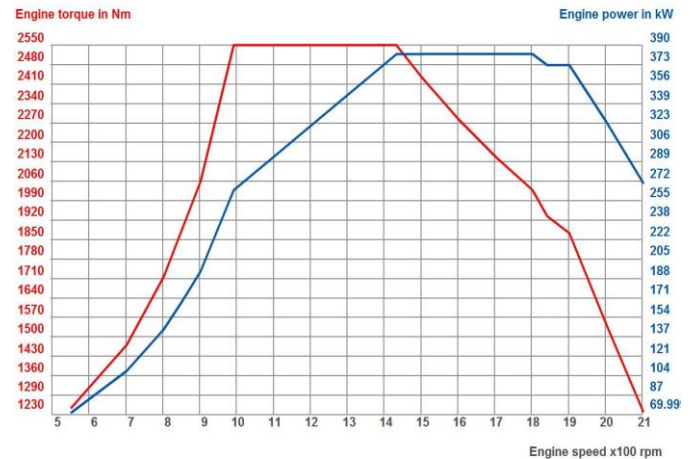

ENGINE EQUIPMENT

Mode Power (Eco - Eco off)
Partial gas recycling (semi-closed circuit)
Without engine Power Take Off.
Electronic speed limiter (90 km/h).

CLUTCH

Single-plate clutch, diameter 430 mm

GEARBOX

Optidriver AT 2612F gearbox (14.94 - 1) with automatic clutch. Aluminium housing.
Max. torque 2550 Nm, 12 forwards gears and 3 reverse gears.
Steering wheel-mounted operating mode selection (automatic/manual) via gear shift selector.
Gearbox rear intermediate housing in aluminium
Gearbox oil cooler, oil/water heat exchanger

RETARDER

OPTIBRAKE+ (power rating 382 kW at 2300 rpm):
combination of the exhaust brake and valve compression braking, coupled to service brake

POWER TAKE-OFF

Power take-off S81
Output: splined hollow shaft (DIN 5462)
Direction of rotation: opposite to engine
Torque: 1000 Nm
Ratios: 0.71/0.90
Position: 18h

STEERING

Power steering, variable-flow hydraulic pump
Steering ratio 20:1 - Steering wheel diameter 460 mm
Driving on the left

FRONT AXLE

Axle with zero-maintenance steering knuckles
Front load capacity (technical max.): 8 t

REAR AXLE

Liftable rear axle
Load transfer to drive axle (10.5 t + 30% if speed below 30 km/h)
Rear axle position : in front of engine drive axle

WHEELS AND TYRES

Dimension 385/55 + 385/55 + 315/70 R22.5
Profile C. ECOREGIONAL HS3 / HD3
Alcoa Dura-Bright aluminium wheels.
Chrome wheel nut protectors with chrome wheel nut caps
Without spare wheel.

REAR DRIVE AXLE

P13170-E single reduction final drive axle
Integral differential lock
Rear loading capacity (technical max.): 19 t
Rear load 7.5t - 11.5t
Drive axle ratio: 2.64
Engine speed at 90 km/h: 1312 rpm

Service brake:

Twin-cylinder air compressor 1100 l/min, 760 cm³
Braking system with two independent circuits.
Ventilated disc brakes.
Electronic management of air production by EACU (Electronic Air Control Unit):
Dryer cartridge optimised by preventive maintenance.
Disengageable air compressor



Aluminium air tanks.

Brake hose couplers, UK standard
Electrical lead with one 15-pin connector to two 7-pin connectors (24N, 24S)
Upward orientation of air hoses
Dummy sockets for electrical cables on DFR
Trailer brake device at cab rear

EBS:

Anti-lock braking system (ABS).
Anti-slip regulation (ASR).
Brake balancing between tractor unit and trailer.
(Disc) brake pad wear compensation
Retarder and service brake linking
Differential engagement management (if equipped) at speeds <10 km/h (4x2)
Hill Start Assist
Braking performance warning
ESC (Electronic Stability Control) trajectory control and anti-rollover system
Coupling traction test
Emergency brake assist (EBA)
Stop lights emergency lighting

Parking brake:

EPB (Electronic Parking Brake) automatic parking brake, immobilization provided by spring cylinders

Brake adjustment:

Automatic brake lining slack compensation.

Emergency brake:

Ensured by independence of main device circuits

CAB**Cab exterior:**

High Sleeper cab
All steel Cab, electro-zinc plated and cathophoretic paint treatment.
Cab paint colour: YELLOW RAL 1021.
Black emblem
Aerodynamic dirt deflectors on the headlamps
4-point cab air suspension with ride-height control system
Electrically operated cab tilt.
Four side storage compartments of which one is accessible from inside the cab
2 heated, remote control rear view mirrors.
2 wide angle rearview mirrors.
Kerb view mirror.
Rear view mirrors for bodywork up to 2.55 m wide
Fold-back front view mirror
Twin air horns - roof mounted.
Spray suppression on front wings
Fixed roof deflector
Side deflectors (2 opening panels)
Door extensions
Exterior parts finished in cab colour
Wide external sun visor
Tinted, laminated windscreen.

Cab interior:

Cab interior finish - Anthracite
Performance roof console, 4 storage compartments with doors including 1 with key lock, 1 storage space with net, 4 ISO modules
Electric interior sun blind on windscreen, manual blinds on driver and passenger side windows
- 7" colour multimedia touchscreen
Pre-equipment for cameras
TV aerial pre-equipment
CB pre-equipment.
DTCO 4.0 digital chronotachograph
Offset 24 V socket
Electrically operated roof hatch with controls at the driver's position and in the bunk area
Mosquito net on air vent
Synthetic carpet floor mats
Heating system (driver's seat)
Ventilation (siège conducteur)
Seat with longitudinal suspension
Two driver's armrests
Red seat belts
Rappel ceinture enclenchée
Air suspension
Adjustable vertical damping
Neck support
Height-adjustable
Easy Access
Stowage on rear of seat back
2 arm rests
Two passenger armrests
Leather seat trim.
Performance lower bunk
Prise soufflette
Grand volume drawer under bunk
Cab interior lighting management rotary control (Activity/Rest/Night driving), brightness adjustment
Reading lamps on overhead console
LED direct and indirect cab lighting
Red night lighting covering 3 rows on the overhead console and on the dashboard
Cab lighting time-delay.
Curtains around cab. Curtain separating driving position from rest area.
Bunk area lighting
Remote control for comfort functions in bunk area with integrated display
Prise 12V & 5V (couchette)
Provision for 50A max. electrical power supply
40L refrigerator in central storage under bench, quiet with thermostat and vehicle battery management
2 storage boxes under bunk, one accessible from interior and exterior
One-touch electric windows
Cab independent night heater air/air (2 kW)
Electronically regulated comfort air conditioning with compressor optimisation
Cab air filtration
Handbook and Service pack in English.

4 loudspeakers and 2 tweeters

Steering wheel equipment:

- Ultimate leather steering wheel*
- OPTIDRIVER control
- OPTIBRAKE and retarder control on right-hand side
- Easy Access steering column adjustable in 3 directions
- Removable writing board on steering wheel*
- ROADPAD+:
 - *HGV-specific TOM TOM navigation system*
 - *FM and DAB+ radio*
 - *USB port and jack socket*
 - *dual Bluetooth connection*

Instrument panel:

- Panoramic dashboard including:
- large central storage.
 - drawer (capacity 2 litres), transformable into ISO module for supplementary equipment.
 - storage tray chilled by air conditioning (capacity 9.4 litres) .
 - cup or movable ashtray location.
 - A4 size paper storage space (capacity 10 litres).
 - 7" HD colour information display
 - Speedometer in miles
 - 12 V + 24 V socket on dashboard, for accessories.
 - Starting inhibitor controlled by transponder key.
 - Remote control central door locking with folding key
 - Bouton de démarrage
 - Cruise control and speed limiter configurable by rotary control
 - Mode Power (Eco - Eco off)
 - Sans mode Eco

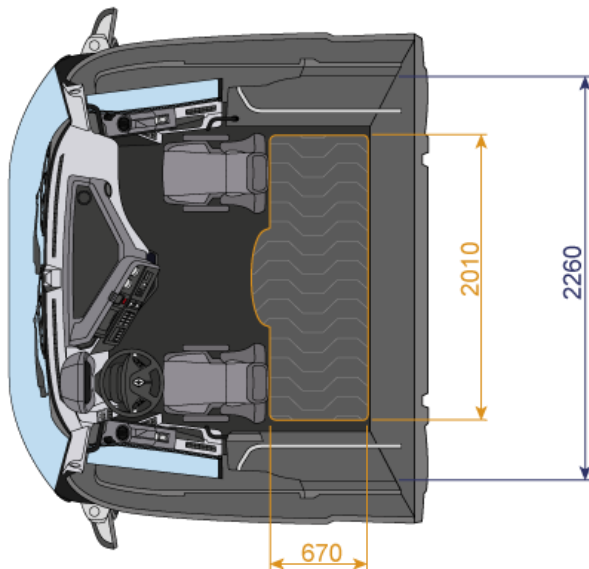
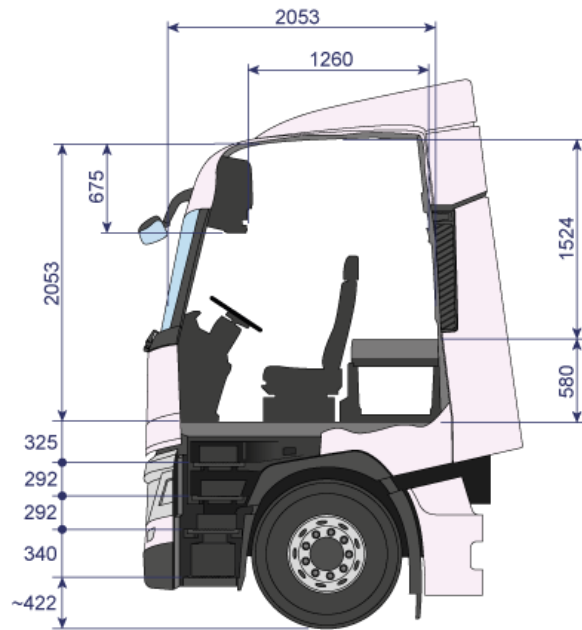

ELECTRONIC EQUIPMENT:

- English and French language display
- Additional language (Spanish)
- SAE cab socket for vehicle data extraction
- FMS Gateway fleet management interface 3.0*
- Assistance button for geolocation via the 24/7 platform
- Lane Departure Warning System (LDWS)
- Adaptive cruise control (ACC) linked to advanced emergency braking system (AEBS)*

ELECTRICAL EQUIPMENT

- Batteries located in the rear overhang
- Two 12 V, 210 Ah, 800 A gel batteries
- Maintenance-free batteries
- Battery cut-out remote control
- Electrical circuit automatically goes to standby
- Battery charge indicator
- Alternator : 150 amp capacity.
- LED rear signalling and lighting (EEC standard e2 10113)*

CHASSIS

- Chassis protective paintwork, mineral grey colour
- technical code: 03650
- Removable front towing cap.
- Front under-run protection.
- Transmission crossmember Reinforced
- Closing cross member with pre-drilling for towing yoke
- Manual sliding medium fifth wheel mounting H=50 mm
- Sheet metal Fontaine SP150 (sheet metal) 2" fifth wheel, D 150 kN
- Fifth wheel position: Y = 550 mm
- Extended rear platform.*



Extension de passage de roue
Rear wings with anti-spray
Wings fitted in standard position.
Side exhaust.

BUMPER - STEPS AND LIGHTING

Plastic bumper with integral spoiler
Retractable windscreen access step in radiator grille
Access to driving position by 4 steps
Step lighting.
Metallic door sills
BUMPER CORNERS, CENTER, AND STEPS PAINTED IN CAB COLOR
Automatic windscreen wiping with rain sensor and automatic illumination of lights
Electrical headlamp levelling control.
LED day running lights
Provision for lighting rail on front end
White LED work light (850 lm)
Front fog lights.
Fixed Bending Lights
Feux à LED
Roof beacon pre-equipment

SUSPENSION

Front suspension

2-leaf front leaf springs
Stabiliser bar

Rear suspension:

Air suspension
Suspension remote control (2 channels).

FUEL TANK

Main aluminium tank
Main fuel tank: 480 litres capacity D710 profile mounted on left & with access steps
Anti-siphoning device
Heavy duty sedimenter and prefilter (R90).Bleed control on dashboard.

AdBlue

63-litre AdBlue tank
Urea tank at the rear right-hand of the cab
63-litre capacity

STANDARD EQUIPMENT

Tool kit.
Reversing warning buzzer, including night switch.

BODYWORK

Orange LED side marker lights with reflector
Interface for bodybuilder connections and BBM module (Body Builder Module)

SERVICE

Optifleet:

Optifleet Check: technical data reports for fuel consumption monitoring by vehicle and by driver, 2-year prepaid subscription

GEARBOX RATIOS

1	2	3	4	5	6	7	8	9	10	11	12
14.94	11.73	9.04	7.09	5.54	4.35	3.44	2.70	2.08	1.63	1.27	1.00

The manufacturer reserves the right to modify the specifications above without prior notice.

Non contractual document.

For further assistance please contact Product Applications at Renault Trucks UK Limited, Wedgnoek Lane , Warwick , CV34 5YA Telephone +44 (0)1926 475333.

