

Model code : UKM_10XC036UK136
Print date: 05/01/2022
Last updated: 05/01/2022

Prepared for :

T HIGH T6X2 PUSHER TML E6 RHD - GVW 23.4 T / GTW 44 T

RENAULT TRUCKS

T HIGH 520



WEIGHTS

Wheelbase		mm	3.900
Maximum Weight (registered)	Total (GVW)	Kg	23400
Payload	(C)	Kg	14725
Maximum Weight (registered)	Front axle 1	Kg	8000.00
	rear axle 1	Kg	7500
	rear axle 2	Kg	11500
Min. weight complete vehicle unladen Kerb Weight	Front axle(s)	Kg	7133.00
	total	Kg	8675
Chassis cab kerb weight	Front Axle 1	Kg	5494.00
	Rear Axle 1	Kg	1256.00
	Rear Axle 2	Kg	1925.00
	Front axles (Liftable axle down)	Kg	5494
	Rear axles (Liftable axle down)	Kg	3181
	Front axles (Liftable axle up)	Kg	5846.00
Total vehicle weight under full load at YMIN	Rear axles (Liftable axle up)	Kg	2754.00
	Front axle(s)	Kg	
Total vehicle weight under full load at YMAX	Rear axle(s)	Kg	
	Front axle(s)	Kg	
	Rear axle(s)	Kg	

This table includes the weights of the RENAULT TRUCKS options: full urea tank, oil, screen wash fluid and coolant at 100%, fuel fill level 90% and driver present (75 kg)



To maintain the driving comfort (lightness of steering, braking) of vehicles in all load and driving conditions once the vehicle is bodied, the following minimum axle load(s) must be respected: A value corresponding to 26% of the weight of the unladen bodied vehicle kerb weight (with driver, without passenger)

LENGTHS

Wheelbase		mm	3.900
Front Overhang	(H / BEP L016)	mm	1365
Wheelbase	(F / BEP L011)	mm	3900
Axle Spacing	Axle 2-3 (BEP L012.2)	mm	1325.00
Rear overhang	Chassis	mm	1046
Centre of Gravity of vehicle	at X (BEP L044)	mm	1249.00
Technical wheelbase	(F' / BEP L015)	mm	3377
Overall Chassis Length	(A / BEP L001)	mm	6311

HEIGHTS

Wheelbase		mm	3.900
Ground clearance, laden	Front (U1 / BEP H015)	mm	192
	Rear (U3 / BEP H016)	mm	215
Max. exterior height unladen	(BEP H001)	mm	3935
Max. exterior height, cab tilted, unladen	(O1 / BEP H061)	mm	4538.00
Cab height (unladen)	(O)	mm	3846
Distance from ground to lowest point at front of vehicle	Unladen (H0 / BEP H18)	mm	304.00
	Laden (H0 / BEP H18)	mm	297.00
Frame top height at front axle	Unladen (H1 / BEP H035)	mm	956.00
	Laden (H1 / BEP H036)	mm	946.00
Frame top height at drive axle	Unladen (H2 / BEP H037)	mm	973
	Laden (H2 / BEP H038)	mm	952
Frame top height at the rear of the frame	Unladen (HN)	mm	977.00
	Laden (HN)	mm	953.00
Centre of Gravity of vehicle	Unladen at Z (BEP H044)	mm	933.00
Side member height	(BEP H032)	mm	300.00

TOWING DEVICE

Wheelbase		mm	3.900
Distance between the front of the vehicle and the centre of the trailer coupling device	(BEP L073 + L016)	mm	4715.00
Distance between centre of last axle to centre of coupling device		mm	
Fifth wheel height, from top of side member	(BEP H074 + H071)	mm	270.00
Fifth wheel height from ground	Unladen (BEP H076)	mm	1240
	Laden (BEP H078)	mm	1221
Swept Swing Clearance	(BEP L078)	mm	
Fifth wheel position	Max. (Ymax / BEP L075)	mm	1100
Gross Vehicle Weight	at YMAX	Kg	23400.00
Gross Vehicle Weight, load on front axle(s)	at YMAX	Kg	8000.00
Gross Vehicle Weight, load on rear axle(s)	at YMAX	Kg	15400.00
King Pin Load	at YMAX	Kg	14725.00
King Pin Load on Front Axle(s)	at YMAX	Kg	2506.00
King Pin Load on RearAxle(s)	at YMAX	Kg	12219.00
Fifth wheel position	Min. (Ymin / BEP L077)	mm	550
Gross Vehicle Weight	at YMIN	Kg	23400.00
Gross Vehicle Weight, load on front axle(s)	at YMIN	Kg	4400.00
Gross Vehicle Weight, load on rear axle(s)	at YMIN	Kg	19000.00
King Pin Load	at YMIN	Kg	14725.00
King Pin Load on Front Axle(s)	at YMIN	Kg	-1094.00
King Pin Load on RearAxle(s)	at YMIN	Kg	15819.00

Fifth wheel position	Manufacturer's recommendation (Y / BEP L076)	mm	550
Gross Vehicle Weight	in fifth wheel position recommended by manufacturer	Kg	23400.00
Gross Vehicle Weight, load on front axle(s)	in fifth wheel position recommended by manufacturer	Kg	7892.00
Gross Vehicle Weight, load on rear axle(s)	in fifth wheel position recommended by manufacturer	Kg	15508.00
King Pin Load	in fifth wheel position recommended by manufacturer	Kg	14725.00
King Pin Load on Front Axle(s)	in fifth wheel position recommended by manufacturer	Kg	2398.00
King Pin Load on RearAxle(s)	in fifth wheel position recommended by manufacturer	Kg	12327.00
Fifth wheel position	Intermediate 1	mm	500.00
Gross Vehicle Weight	in intermediate fifth wheel position 1	Kg	23400.00
Gross Vehicle Weight, load on front axle(s)	in intermediate fifth wheel position 1	Kg	7674.00
Gross Vehicle Weight, load on rear axle(s)	in intermediate fifth wheel position 1	Kg	15726.00
King Pin Load	in intermediate fifth wheel position 1	Kg	14725.00
King Pin Load on Front Axle(s)	in intermediate fifth wheel position 1	Kg	2180.00
King Pin Load on RearAxle(s)	in intermediate fifth wheel position 1	Kg	12545.00
Fifth wheel position	Intermediate 2	mm	450.00
Gross Vehicle Weight	in intermediate fifth wheel position 2	Kg	23400.00
Gross Vehicle Weight, load on front axle(s)	in intermediate fifth wheel position 2	Kg	7456.00
Gross Vehicle Weight, load on rear axle(s)	in intermediate fifth wheel position 2	Kg	15944.00
King Pin Load	in intermediate fifth wheel position 2	Kg	14725.00
King Pin Load on Front Axle(s)	in intermediate fifth wheel position 2	Kg	1962.00
King Pin Load on RearAxle(s)	in intermediate fifth wheel position 2	Kg	12763.00
Sliding fifth wheel	front fork	mm	4.71
	rear yoke	mm	4.05

WIDTHS

Wheelbase		mm	3.900
Max exterior cab width with rear view mirrors open	(BEP W001)	mm	2960.00
Max. cab width	(BEP W002)	mm	2534
Frame width	Front (BEP W035)	mm	1080
	Rear (BEP W036)	mm	850
Width at rear wheels	Rear axle 1 (V3 / BEP W003.2)	mm	2490
	Rear axle 2 (V5 / BEP W003.3)	mm	2518.00
Track	Front (V1 / BEP W013.1)	mm	2109
	Rear 1 (V2 / BEP W013.2)	mm	2104
	Rear 2 (V4 / BEP W013.2)	mm	1854.00

OTHER

Wheelbase		mm	3.900
Approach angle	(BEP H010)	°	11
Ramp angle	(BEP H012)	°	20.80
Departure angle	(BEP H011)	°	17.70
Side member thickness	(BEP W034)	mm	7.00
Turning Radius	Overall (BEP W012)	mm	6900.00
	kerb to kerb	mm	6243.00
	interior	mm	2633.00

DTI 13 ENGINE

Max. power: 382 kW from 1430 to 1800 rpm

Max. torque: 2550 Nm from 1000 rpm to 1430 rpm

Power output (UK): 512 hp

6-cylinder in-line diesel engine - Common rail high-pressure fuel-injection (2000 bar) - 24 valves - overhead camshaft, rear-mounted timing

High pressure provided by three pumps on injector bodies.

Bore 131 mm - stroke 158 mm - Capacity 12.8 L

Electronically-controlled fan

Turbocharger

Direction of rotation (seen from gearbox end): anti-clockwise

Oil filter with additive

EEC EURO VI pollution control level

Compact after-treatment system (catalytic converter, DPF, SCR)

Cooling liquid

Automatic regeneration of particulate filter



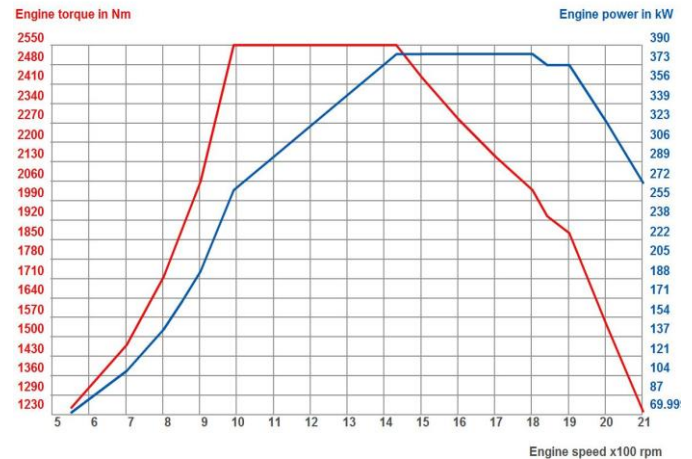

ENGINE EQUIPMENT

Power mode inhibited after passing the 'hard spot' of the accelerator pedal

Partial gas recycling (semi-closed circuit)
Automatic engine cut-off (5 min)
Without engine Power Take Off.
Electronic speed limiter (90 km/h).

CLUTCH

Single-plate clutch, diameter 430 mm

GEARBOX

Optidriver AT 2612F gearbox (14.94 - 1) with automatic clutch. Aluminium housing.
Max. torque 2550 Nm, 12 forwards gears and 3 reverse gears.
Steering wheel-mounted operating mode selection (automatic/manual) via gear shift selector.
Optivision Map Based gear shift strategy for FUEL ECO (anticipation of topography and centralised data storage).
Gearbox rear intermediate housing in aluminium
Gearbox oil cooler, oil/water heat exchanger

RETARDER

OPTIBRAKE+ (power rating 382 kW at 2300 rpm): combination of the exhaust brake and valve compression braking, coupled to service brake

POWER TAKE-OFF

Without gearbox mounted PTO

STEERING

Hydraulic power steering, variable flow pump

Steering ratio 20:1 - Steering wheel diameter 460 mm
Driving on the left

FRONT AXLE

Axle with zero-maintenance steering knuckles
Front load capacity (technical max.): 8 t

REAR AXLE

Liftable rear axle
Load transfer to drive axle (10.5 t + 30% if speed below 30 km/h)
Rear axle position : in front of engine drive axle

WHEELS AND TYRES

Dimension 385/55 + 385/55 + 315/70 R22.5
Profile M. XLINE ENERGY F (ANTISPLASH) / D2
Alcoa Dura-Bright aluminium wheels.
ISO_11992 compatible tyre pressure monitoring system
Chrome wheel nut protectors with chrome wheel nut caps
Without spare wheel.

REAR DRIVE AXLE

P13170-E single reduction final drive axle
Integral differential lock
Rear loading capacity (technical max.): 19 t
Rear load 7.5t - 11.5t
Drive axle ratio: 2.47
Engine speed at 90 km/h: 1228 rpm

Service brake:

Twin-cylinder air compressor 900 l/min, 636 cm³
Braking system with two independent circuits.
Ventilated disc brakes.
Electronic management of air production by EACU (Electronic Air Control Unit):
Dryer cartridge optimised by preventive maintenance.
Disengageable air compressor



Aluminium air tanks.

Brake hose couplers, UK standard
Electrical lead with one 15-pin connector to two 7-pin connectors (24N, 24S)

Downward orientation of air hoses

Dummy sockets for electrical cables on DFR
Trailer brake device at cab rear, in aluminium

EBS:

Anti-lock braking system (ABS).
Anti-slip regulation (ASR).
Brake balancing between tractor unit and trailer.
(Disc) brake pad wear compensation
Retarder and service brake linking
Differential engagement management (if equipped) at speeds <10 km/h (4x2)
Hill Start Assist
Braking performance warning
ESC (Electronic Stability Control) trajectory control and anti-rollover system
Coupling traction test
Emergency brake assist (EBA)
Stop lights emergency lighting

Parking brake:

EPB (Electronic Parking Brake) automatic parking brake, immobilization provided by spring cylinders

Brake adjustment:

Automatic brake lining slack compensation.

Emergency brake:

Ensured by independence of main device circuits

CAB**Cab exterior:**

High Sleeper cab
All steel Cab, electro-zinc plated and cathaphoretic paint treatment.
*Cab paint colour: Grey metallic corail
technical code: 03721
Black emblem*
Aerodynamic dirt deflectors on the headlamps
4-point cab air suspension with ride-height control system
Electrically operated cab tilt.
Four side storage compartments of which one is accessible from inside the cab
2 heated, remote control rear view mirrors.
2 wide angle rearview mirrors.
Kerb view mirror.
Rear view mirrors for bodywork up to 2.55 m wide
Fold-back front view mirror
*Twin air horns - roof mounted.
Laminated side windows.*
Spray suppression on front wings
*Fixed roof deflector
Side deflectors (2 opening panels)*
Door extensions
Cab accessories: cab colour

Wide external sun visor
Tinted, laminated windscreen.

Cab interior:

Performance roof console, 4 storage compartments with doors including 1 with key lock, 1 storage space with net, 4 ISO modules
*Electric interior sun blind on windscreen, manual blinds on driver and passenger side windows
- 7" colour multimedia touchscreen
Pre-equipment for cameras*
DTCO 4.0 digital chronotachograph
Offset 24 V socket
Electrically operated roof hatch with controls at the driver's position and in the bunk area
Mosquito net on air vent
Synthetic carpet floor mats
*Seat with longitudinal suspension
Two driver's armrests
Safety belt warning.
Two passenger armrests*
Leather seat trim.
Performance lower bunk
*Ultimate upper bunk, transformable into storage with access ladder and luggage net
Removable back rest*
Grand volume drawer under bunk
*Cab interior lighting management rotary control (Activity/Rest/Night driving), brightness adjustment
Reading lamps on overhead console
LED direct and indirect cab lighting
Red night lighting covering 3 rows on the overhead console and on the dashboard*
Cab lighting time-delay.
*Curtains with insulation around the cab and bunk separation
Articulated LED lamps in bunk area
Remote control for comfort functions in bunk area with integrated display
Provision for 50A max. electrical power supply
40L refrigerator in central storage under bench, quiet with thermostat and vehicle battery management*
2 storage boxes under bunk, one accessible from interior and exterior
*One-touch electric windows
Cab independent night heater air/air (2 kW)
Reinforced heat insulation
Electronically regulated comfort air conditioning with compressor optimisation
Cab air filtration, washable filter*
Handbook and Service pack in English.
4 loudspeakers and 2 tweeters
Fire extinguisher 3kg

Steering wheel equipment:
Ultimate leather steering wheel
OPTIDRIVER control
OPTIBRAKE and retarder control on right-hand side
Easy Access steering column adjustable in 3 directions
Removable writing board on steering wheel
ROADPAD+:
- HGV-specific TOM TOM navigation system



- FM and DAB+ radio
- USB port and jack socket
- dual Bluetooth connection

Instrument panel:

- Panoramic dashboard
- 7" HD colour information display
- Speedometer in miles
- 12 V + 24 V socket on dashboard, for accessories.
- Starting inhibitor controlled by transponder key.
- Remote control central door locking with folding key
- Two additional ignition keys
- ECO Cruise control with Optiroll

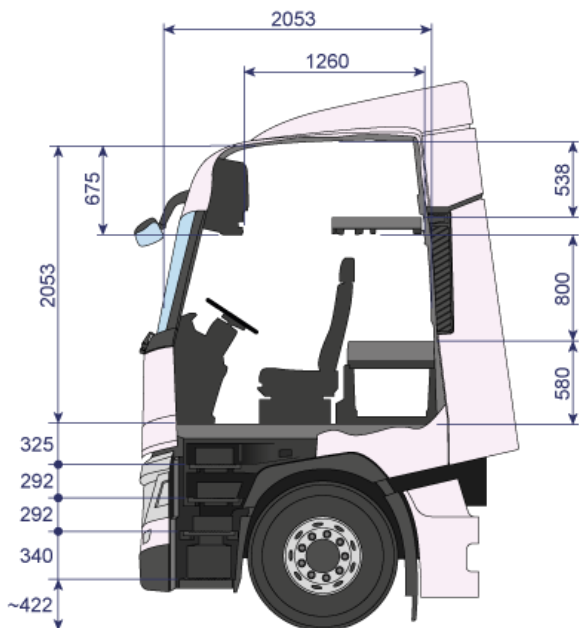
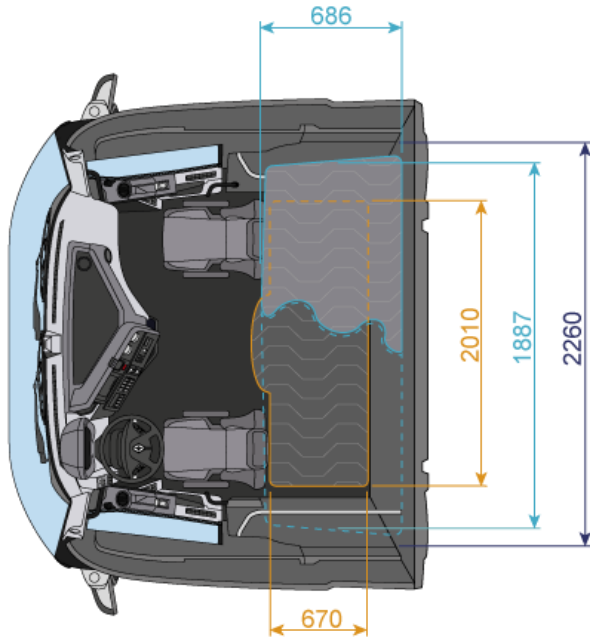

ELECTRONIC EQUIPMENT:

- English and French language display
- Additional language (Polish)
- SAE cab socket for vehicle data extraction
- Load per axle indicator
- FMS Gateway fleet management interface 3.0
- Assistance button for geolocation via the 24/7 platform
- 4G TGW telematics unit (telematic gateway) including an antenna and enabling subscription to Optifleet services (Map, Check, Drive)
- Lane Departure Warning System (LDWS)
- Adaptive cruise control (ACC) linked to advanced emergency braking system (AEBS)

ELECTRICAL EQUIPMENT

- Batteries located in the rear overhang
- Two 12 V, 210 Ah, 800 A gel batteries
- Maintenance-free batteries
- Battery cut-out remote control
- Electrical circuit automatically goes to standby
- Battery charge indicator
- Alternator : 150 amp capacity.
- LED rear signalling and lighting (EEC standard e2 10113)

CHASSIS

- Chassis protective paintwork, mineral grey colour
- technical code: 03650
- Removable front towing cap.
- Front under-run protection.
- Transmission crossmember Reinforced
- Closing cross member with pre-drilling for towing yoke
- Pneumatic sliding medium fifth wheel mounting H=50 mm
- Jost JSK 36D (sheet metal), 2" sheet metal fifth wheel, D 152 kN
- Fifth wheel position: Y = 550 mm
- Extended rear platform.
- Rear wings with anti-spray
- Wings fitted in standard position.
- Side exhaust.

BUMPER - STEPS AND LIGHTING

- Plastic bumper with integral spoiler
- Retractable windscreen access step in radiator grille
- Access to driving position by 4 steps
- Step lighting.
- Metallic door sills
- Automatic windscreen wiping with rain sensor and automatic illumination of lights
- Electrical headlamp levelling control.
- LED day running lights
- Provision for lighting rail on roof
- White LED work light (850 lm)
- Front fog lights.
- Roof beacon pre-equipment



Integrated headlamp washer

SUSPENSION

Front suspension

2-leaf front leaf springs
Stabiliser bar

Rear suspension:

Air suspension
Stabiliser bar
Suspension remote control (2 channels).

FUEL TANK

Main aluminium tank
Main fuel tank: 480 litres capacity D710 profile mounted on left & with access steps
Heavy duty sedimenter and prefilter (R90).Bleed control on dashboard.

AdBlue

64-litre AdBlue tank (D710)
Urea tank on the right

1	2	3	4	5	6	7	8	9	10	11	12
14.94	11.73	9.04	7.09	5.54	4.35	3.44	2.70	2.08	1.63	1.27	1.00

*The manufacturer reserves the right to modify the specifications above without prior notice.**Non contractual document.**For further assistance please contact Product Applications at Renault Trucks UK Limited, Wedgnock Lane , Warwick , CV34 5YA Telephone +44 (0)1926 475333.*

STANDARD EQUIPMENT

Tool kit.
Reversing warning buzzer, including night switch.

BODYWORK

Bodybuilder access through bulkhead
Provision for rear loading lighting
Orange LED side marker lights with reflector
Interface for bodybuilder connections and BBM module (Body Builder Module)

SERVICE

Optifleet:

Optifleet Check: technical data reports for fuel consumption monitoring by vehicle and by driver, 2-year prepaid subscription
Optifleet Map: vehicle geolocation, geofencing and route analysis, 2-year prepaid subscription

GEARBOX RATIOS

