

RENAULT TRUCKS E-TECH D & D WIDE



renault-trucks.co.uk

ELECTROMOBILITY WITH RENAULT TRUCKS

With its electric vehicle range, Renault Trucks offers zero emissions vehicles that can be driven regardless of any emissions restrictions within built-up areas. Renault Trucks E-Tech vehicles help to reduce congestion and preserve air quality: they are silent, enabling quiet night deliveries, and their powertrain produces no local polluting emissions.



**A PIONEER IN
ELECTRIC MOBILITY
SINCE 2010**

**FIRST RANGE OF
ELECTRIC VEHICLES
BUILT IN PRODUCTION**



RENAULT TRUCKS E-TECH MASTER



**70% NOISE REDUCTION
INSIDE THE CAB FOR
IMPROVED COMFORT
AND PEACE OF MIND
AT THE WHEEL**



RENAULT TRUCKS E-TECH D



RENAULT TRUCKS E-TECH D WIDE

THE TRANSITION TO ELECTRIC MADE EASY...

SUPPORT TAILORED TO YOUR NEEDS

Renault Trucks has a range of experts on hand to guide you through your energy transition. With a 360° approach over 4 stages, you will never be on your own when it comes to going carbon neutral:



YOUR TURNKEY RECHARGING SOLUTIONS PARTNER

With the support of its partners*, Renault Trucks can help with the installation and maintenance of your charging infrastructure:

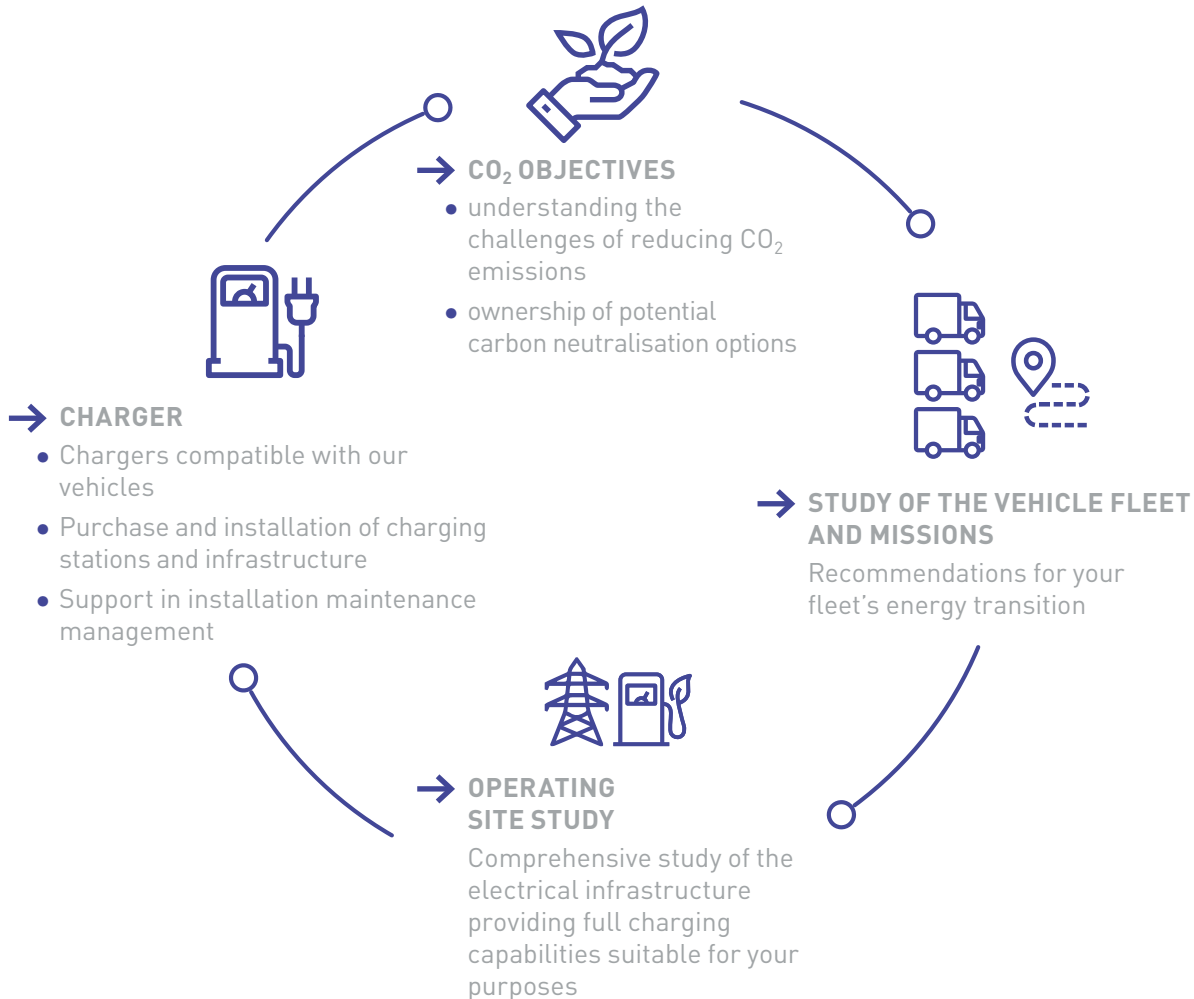

ADVICE ON FINANCING YOUR ELECTRIC VEHICLES

Benefit from support tailored to your needs across all aspects of financing to facilitate your transition to electric vehicles.

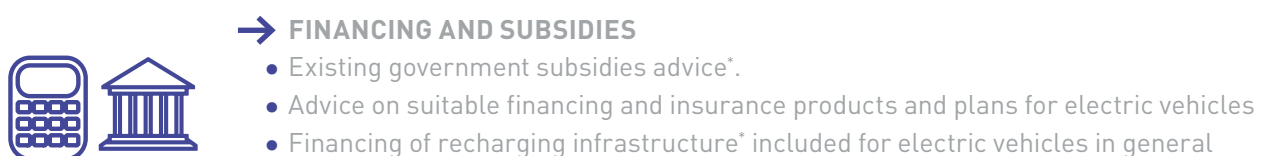

With fixed monthly payments that include financing, insurance, a maintenance contract and a battery performance guarantee, Renault Trucks Financial Services offers you the opportunity to switch to electric vehicles with complete peace of mind.

* Available depending on the country.

...WITH ELECTROMOBILITY EXPERTS WORKING WITH YOU

ADVICE ON ASSESSING THE RANGE OF YOUR VEHICLES

Because range is always an important consideration when looking to buy an electric vehicle, Renault Trucks will work with you every step of the way, with tools enabling you to assess the distance you can cover based on your vehicle usage.

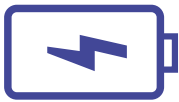

→ EXPLORE THE MAXIMUM RANGE OF OUR E-TECH PRODUCTS

- Visit the Renault Trucks website to try out our range simulation tool, which provides an indication of the range for any E-Tech vehicle based on your route and requirements.



CLICK HERE TO GO TO IT DIRECTLY

Model

Usage

Operation

Temperature : 20*

Load : 75%

Given those criteria, here is the expected maximum operating range of your truck:

0km 360-380 km 450km

The indicated range depends on the individual use of the vehicle, its equipment and other external factors. For each model, the range is calculated at the beginning of the battery's life with the maximum number of packs, it is given as an indication and has no contractual value.



→ **DISCOVER THE RANGE CAPABILITIES OF AN E-TECH VEHICLE BASED ON REAL SCENARIOS AND USAGE**

- With our "Range Simulator" tool, our experts will analyse the vehicle's energy consumption to match its actual use as closely as possible, based on a GPS route and any events that may impact on the vehicle's energy consumption (weather, changes in payload, use of auxiliary devices that use electrical power, etc.)
- Easy to understand and highly visual, the simulation tool's results will enable you to plan your future vehicle use over the course of a whole year and over the life of your vehicle

→ **RANGE SIMULATION EXAMPLE**

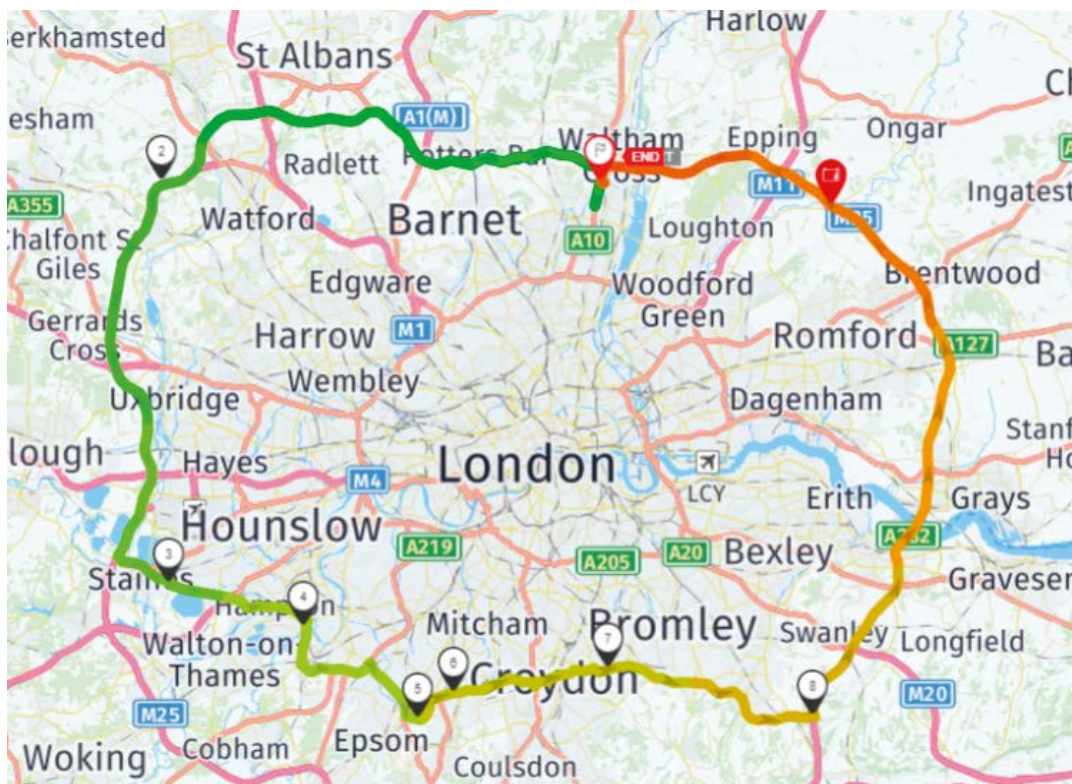

...WITH ELECTROMOBILITY EXPERTS WORKING WITH YOU

ADVICE ON OPTIMISING TCO AND YOUR CARBON FOOTPRINT

Renault Trucks can help you calculate the total cost of ownership (TCO*) of your electric vehicle solution and evaluate the associated CO₂ savings. With our custom-built tool, the "TCO2 Calculator", our experts can provide you with the best possible view of your transition to electromobility:



→ GET AN EASILY UNDERSTANDABLE COMPARISON

The closest possible view of the TCO of an E-Tech truck compared to a diesel or gas truck

→ EASILY ADJUST THE VARIOUS FACTORS THAT IMPACT TCO:

Duration, miles/kilometres, energy cost, simulation of the different purchasing subsidies and tax breaks



→ CALCULATE AND COMPARE CO₂ EMISSIONS

For the different energy sources over the lifetime of the vehicle, based on a variety of scenarios. The results of the simulation will give you a quick idea of the total costs, energy costs and potential CO₂ reductions



EXCERPT FROM THE "TCO2 CALCULATOR" REPORT - SIMULATION

Total cost of ownership over 5 years - Unladen space and tailgate - 45,000 km/year

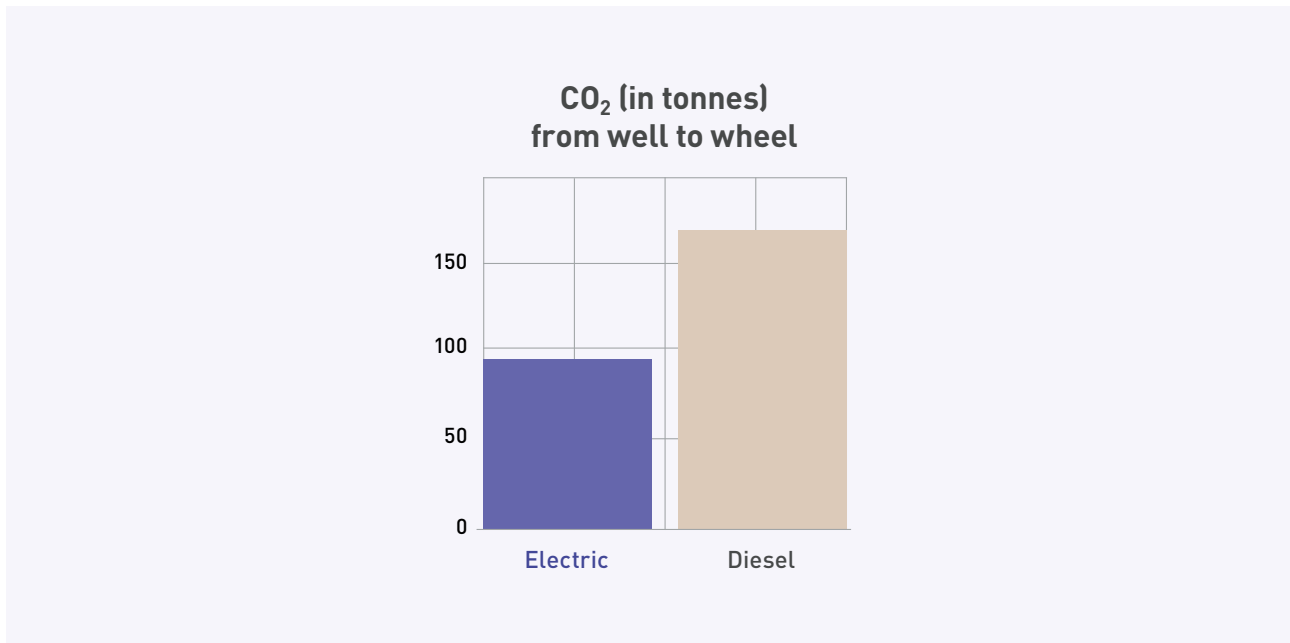
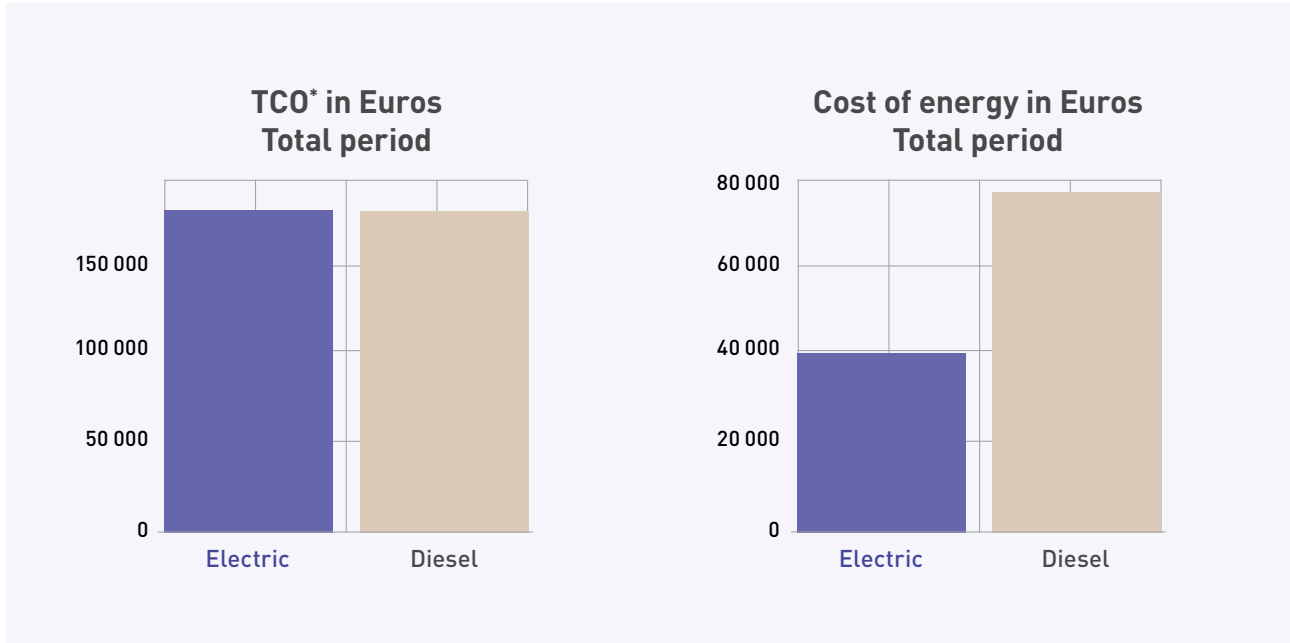

* Total cost of ownership.

THE ALL-PURPOSE ELECTRIC SOLUTION

With their lower operating costs, diverse range options and safe payload, Renault Trucks E-Tech D and D Wide can easily meet your needs and enable you to switch to electric vehicles in full peace of mind.



→ LOWER OPERATING COSTS

Lower energy and maintenance costs, providing a competitive TCO.



→ EXTREMELY QUIET

for deliveries in towns and cities during off-peak hours without disturbing local residents.

ZERO EMISSIONS FOR LOW EMISSION ZONES

A RANGE OF UP TO 560 KM*

RENAULT TRUCKS E-TECH D



- **AC CHARGE (alternative current)**
Built-in charger - 22 kW
- **DC CHARGE (direct current)**
Maximum power - 150 kW
- **WHEELBASE**
from 3800mm to 6500mm
- **1 ELECTRIC MOTOR**
Max. power output: 185 kW
Cont. power : 130 kW
Max. torque: 425 Nm
- **BATTERIES**
200 kWh to 565 kWh
Lithium-ion technology

RENAULT TRUCKS E-TECH D WIDE



- **AC CHARGE (alternative current)**
Built-in charger - 22 kW
- **DC CHARGE (direct current)**
Maximum power - 150 kW
- **WHEELBASE**
from 3900mm to 6800mm
- **2 ELECTRIC MOTORS**
Max. power output: 370 kW
Cont. power : 260 kW
Max. torque: 850 Nm
- **BATTERIES**
200 kWh to 375 kWh
Lithium-ion technology

LOW ENTRY CAB VERSION



- **NEW LOW-LEVEL CAB****
designed to assist with distribution and waste collection tasks while maintaining the safety of operators and vulnerable road users.

85% REDUCTION IN VEHICLE EXTERNAL NOISE

→ ANALYSIS OF VEHICLE LIFE CYCLE***

- 50% reduction in CO₂
- 80% reduction in NO_x

*Renault Trucks E-Tech D with a van body

**Renault Trucks E-Tech Low entry cab based on the Renault Trucks E-Tech D Wide 6x2 26t 2.3m cab. Cab lowered by 200mm and extended by 600mm.

***European electric Mix. The life cycle is calculated by taking into account the manufacturing, the vehicle recycling and the energy produced during the vehicle's life time.

EASY TO RECHARGE

Fully charged in less than two hours on a fast charge or overnight on a standard industrial socket, Renault Trucks E-Tech D and D Wide can work in any situation.

FULL
CHARGE
IN LESS
THAN
2 HOURS*

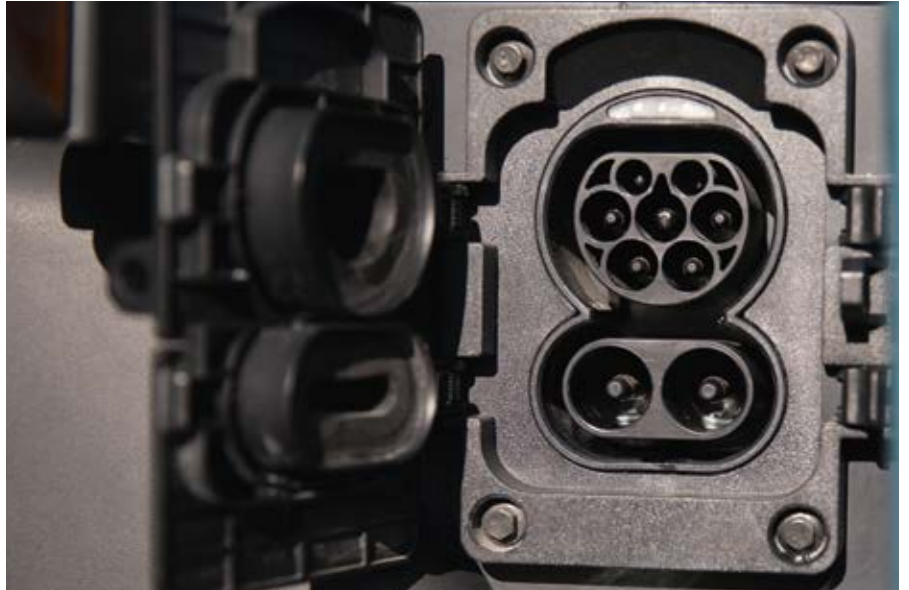

* fast charging

INFORMATION TABLE: CHARGING TIME WILL DEPEND ON THE POWER OF THE CHARGING INSTALLATION AND THE BATTERY

→ 4x 66kWh

Charger	Amperage	50% charge	80% charge
22kW AC**	32 A	5h00	8h30
40kW DC	63 A	2h40	4h15
100kW DC	125 A	1h20	2h00
150kW DC	200 A	0h50	1h20

→ 4x 94kWh

Charger	Amperage	50% charge	80% charge
22kW AC**	32 A	7h20	12h00
40kW DC	63 A	3h45	6h10
100kW DC	125 A	1h50	3h00
150kW DC	225 A	1h10	1h50

** onboard charger



PROVEN TECHNOLOGY

High energy density thanks to lithium-ion cells, offering the best compromise between operating range and payload.



RESPONSIBLE SUPPLY CHAIN

Supply chain audits are conducted to minimise the environmental and societal impact of our suppliers as well as their own suppliers (e.g. Cobalt). The batteries are assembled in Europe. The vehicles are assembled in France.



RESPONSIBLE RECYCLING

Recycling is the responsibility of Renault Trucks as soon as the batteries are returned to Renault Trucks authorised dealers. There are a range of second life options for vehicle batteries, such as stationary energy storage equipment or energy supply for buildings (hospitals, stadiums, housing, etc.)

DRIVE FURTHER AND FOR LONGER

FACTORS THAT HAVE AN IMPACT ON THE OPERATING RANGE:

- SPEED
- TOPOGRAPHY
- WEATHER CONDITIONS
- TRANSPORTED LOAD
- DRIVING STYLE



RECHARGE THE BATTERY WHILE BRAKING

Renault Trucks E-Tech D and D Wide use a regenerative brake and retarder to convert the kinetic energy of deceleration into electrical energy. This means that the truck collects energy and extends its range

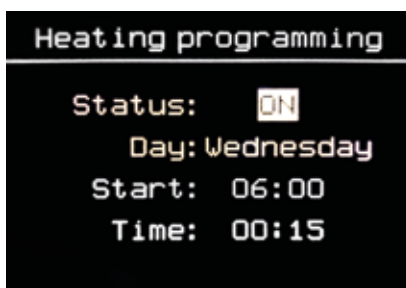

CAB PREHEATING

When the charging cable is connected (whether the vehicle is charging or not), programming the cabin to preheat at a preset time will maintain the vehicle range and improve driver comfort.



VEHICLE HANDOVER AND TRAINING IN ECO-DRIVING

to make the best use of the vehicle.

YOU CAN RELY ON THE RENAULT TRUCKS NETWORK

With almost 1400 services points across Europe, there is always a dealer near you.

A NETWORK EQUIPPED, TRAINED, CLOSE TO YOU AND ALWAYS AVAILABLE

- Expert technicians trained in electrical solutions
- Extended opening hours, including Saturday mornings*
- Fast appointments for repairs and maintenance

*According to Renault Trucks authorised dealers.



QUALITY PARTS AND RELIABLE SERVICE FOR PEACE OF MIND AT WORK



2 YEAR WARRANTY ON OUR PARTS AND LABOUR

2-year parts, breakdown and towing warranty for all operations carried out at an approved Renault Trucks repairer.



ORIGINAL PARTS PACKAGE

Quality original parts: reliable, strong and approved to maintain vehicle performance.



EXCHANGE PACKAGE

Reconditioned parts available to maintain your vehicle performance by giving them a second life.



24/7 BREAKDOWN SERVICE

With a network of experts capable of responding to your needs in 16 languages, a coordinator will be your exclusive point of contact for any work that has to be done. Breakdowns are dealt with by specially trained roadside technicians who use special vehicles and work with dedicated diagnostic tools.

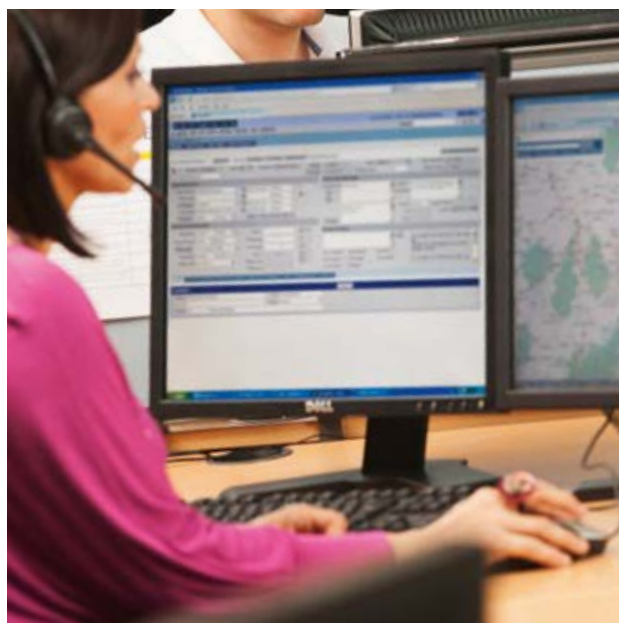

DRIVE WITH COMPLETE PEACE OF MIND

MORE PEACE OF MIND WITH OUR MAINTENANCE CONTRACTS



START & DRIVE

With Start & Drive Excellence contracts, you are choosing maintenance contracts tailored to your individual circumstances. This allows you to control your "maintenance and repair" budget and optimise vehicle availability.

For even more convenience, these contracts also include

→ RENAULT TRUCKS' COMMITMENT TO EASY TRANSPORT ORGANISATION:

guarantee on the minimum amount of energy available after full charge during the entire contract period.

	Minimum available energy commitment after a full charge in kWh	Technical limit of total energy delivered in MWh [*]
200 kWh (3x66 kWh)	126	225
265 kWh (4x66 kWh)	168	300
330 kWh (5x66 kWh)	211	375
400 kWh (6x66 kWh)	253	450
280 kWh (3x94 kWh)	180	300
375 kWh (4x94 kWh)	240	400
470 kWh (5x94 kWh)	300	500
565 kWh (6x94 kWh)	360	600

→ AN ADJUSTABLE MAINTENANCE SCHEDULE TAILORED TO YOUR USAGE

→ OUR BREAKDOWN TOWING PACKAGE (24/7 TOWING ASSISTANCE).



^{*}This value is equal to the total energy extracted from the battery in megawatt-hours (MWh), through the electric driveline, ancillaries and any bodywork equipment.

BOOST YOUR FLEET PERFORMANCE



→ OPTIFLEET CHECK

provides a clear view of vehicle energy consumption.

- > Easy-to-read report
- > Special reports for electric vehicles
- > Monitoring the electric battery charge level



→ WITH OPTIFLEET MAP

- > Use geolocation to optimise your deliveries and monitor in real time: the speed, battery levels, identity and driving time of your drivers.
- > Receive alerts on your battery status (discharged, low level, etc.) and on the beginning and completion of charging.



- Optimise your driver shiftwork
- Improve your service quality
- Increase your efficiency and customer satisfaction



→ OPTIFLEET DRIVE

- > Real-time monitoring of driving and resting times
- > Infringement alerts
- > Remote download of tachograph and driver data

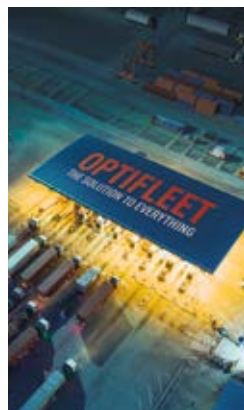

- Respect the working time regulations for drivers
- Save time
- Remote Tachograph Downloading

RANGE OVERVIEW

Cab	Type	Configuration	GCW	GCWR	Chassis	Engine	Power	Batteries	Range
Renault Trucks E-Tech D Cab 2.1m	Rigid	4x2	16t	16t	MEDIUM 19.5" wheels	1 electric motor Maximum torque: 425 Nm	Maximum: 185 kW Continuous: 130 kW	200 kWh to 565 kWh	Up to 560 km
Renault Trucks E-Tech D Wide Cab 2.3m*	Rigid	4x2 6x2	19 t 26 t	19 t 26 t	HIGH 22.5" wheels	2 electric motors Maximum torque: 850 Nm	Maximum: 370 kW Continuous: 260 kW	200 kWh to 375 kWh	Up to 315 km

* Renault Trucks E-Tech D Wide Low entry cab is based on the Renault Trucks E-Tech D Wide 6x2 26t 2.3m cab. Cab lowered by 200 mm and extended by 600 mm.

RENAULT TRUCKS E-TECH D (2.1 M CAB)

DAY CAB

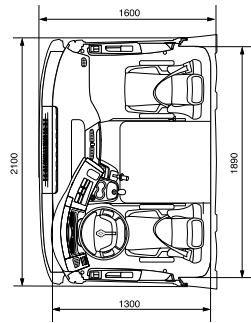
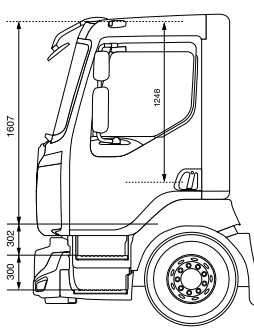

GLOBAL CAB

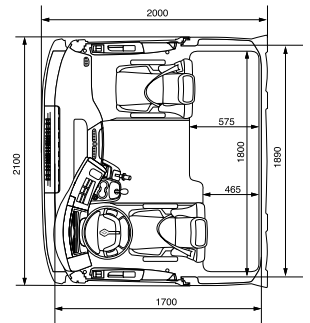
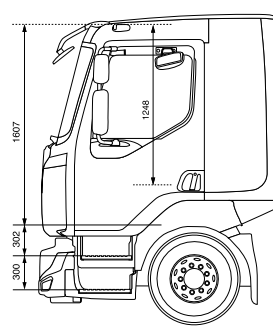

RENAULT TRUCKS E-TECH D WIDE (2.3 M CAB)

DAY CAB

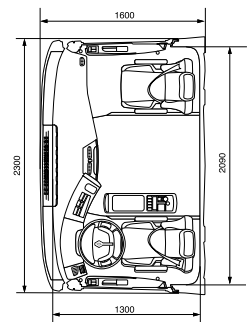
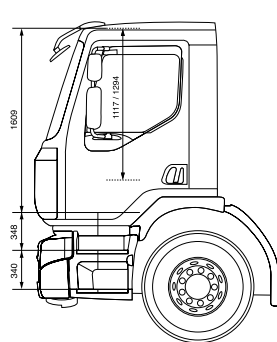

GLOBAL CAB

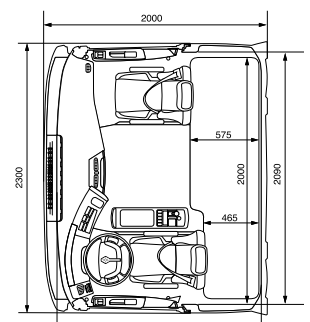
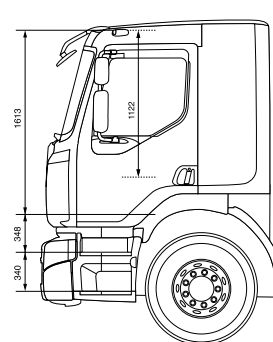

LOW ENTRY CAB

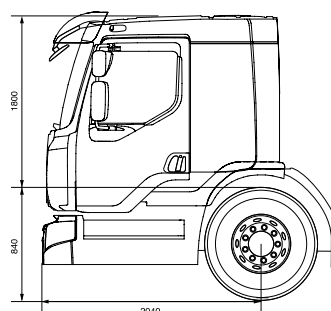

	Renault Trucks E-Tech D	Renault Trucks E-Tech D WIDE	Renault Trucks E-Tech D WIDE
RENAULT TRUCKS E-TECH RANGE			
Total permissible all-up weight	16.7 tonnes	19 tonnes	27 tonnes
5-year Optifleet CHECK	□	□	□
5-year Optifleet MAP+	□	□	□
CAB			
DAY cab	□	□	□
GLOBAL cab	○	○	○
Air conditioning	□	□	□
POWER TRAIN			
1 electric motor (130 kW)	□	-	-
2 electric motors (260 kW)	-	□	□
Rear axle ratio	4.5	5.29	5.29
200 kWh batteries – 3 packs of 66 kWh	○	○	○
265 kWh batteries – 4 packs of 66 kWh	□	□	□
330 kWh batteries – 5 packs of 66 kWh	○	-	-
400 kWh batteries – 6 packs of 66 kWh	○	-	-
280 kWh batteries – 3 packs of 94 kWh	○	○	○
375 kWh batteries – 4 packs of 94 kWh	○	○	○
470 kWh batteries – 5 packs of 94 kWh	○	-	-
565 kWh batteries – 6 packs of 94 kWh	○	-	-
CHASSIS			
Full air suspension	□	□	□
Power take-off (electric motor)	○	○	○
+600 V DC connection (temperature-controlled application 15kW max)	○	○	○
Chassis fairing	□	□	□
Aluminum wheels	□	□	□
Tyre dimensions	285/70	315/70 315/80	315/80
PACKS			
Comfort pack	□	□	□
Safety pack	□	□	□

□ standard ○ optional - not applicable

WHEELBASES

	3800	3900	4100	4300	4400	4500	4700	4750	5000	5250	5300	5500	5600	5800	5900	6100	6200	6450	6500	6800
Renault Trucks E-Tech D 16t 4x2	■		■		■		■		■		■		■		■		■		■	
Renault Trucks E-Tech D Wide 19t 4x2		■	■	■		■		■	■	■		■		■		■		■		■
Renault Trucks E-Tech D Wide 26t 6x2		■	■	■		■		■	■	■		■		■		■				

■ Wheelbases available



We recommend Renault Trucks Oils.
Dimensions and specifications are provided for guidance only.
The manufacturer reserves the right to change them without prior notice.



renewalt-trucks.co.uk



11/2022