

Model code : UKM_10XC036STPUS
Print date: 21/01/2026
Last updated: 21/01/2026

Prepared for :

RENAULT TRUCKS T HIGH T6X2 PUSHER 13L E6 - GVW 23.4 T / GCW 44 T

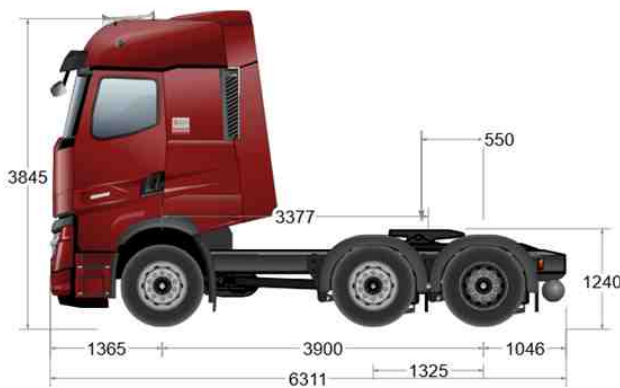

WEIGHTS

Wheelbase		mm	3.900
Maximum Weight (registered)	Total (GVW)	Kg	23400
Payload	(C)	Kg	14169
Maximum Weight (registered)	Front axle 1	Kg	8000.00
	rear axle 1	Kg	7500
	rear axle 2	Kg	11500
Min. weight complete vehicle unladen	Front axle(s)	Kg	7133.00
Kerb Weight	total	Kg	9231
Chassis cab kerb weight	Front Axle 1	Kg	5756.00
	Rear Axle 1	Kg	1372.00
	Rear Axle 2	Kg	2103.00
	Front axles (Liftable axle down)	Kg	5756
	Rear axles (Liftable axle down)	Kg	3475
	Front axles (Liftable axle up)	Kg	6147.00
Total vehicle weight under full load at YMIN	Rear axles (Liftable axle up)	Kg	3009.00
	Front axle(s)	Kg	
Total vehicle weight under full load at YMAX	Rear axle(s)	Kg	
	Front axle(s)	Kg	



	Rear axle(s)	Kg	
--	--------------	----	--

This table includes the weights of the RENAULT TRUCKS options: full AdBlue tank, oil, screen wash fluid and coolant at 100%, fuel fill level 90% and driver present (75 kg)
To maintain the driving comfort (lightness of steering, braking) of vehicles in all load and driving conditions once the vehicle is bodied, the following minimum axle load(s) must be respected: A value corresponding to 26% of the weight of the unladen bodied vehicle kerb weight (with driver, without passenger)

LENGTHS

Wheelbase		mm	3.900
Front Overhang	(H / BEP L016)	mm	1365
Wheelbase	(F / BEP L011)	mm	3900
Axle Spacing	Axle 2-3 (BEP L012.2)	mm	1325.00
Rear overhang	Chassis, overall (BEP L017)	mm	1046
Centre of Gravity of vehicle	at X (BEP L044)	mm	1282.00
Technical wheelbase	(F' / BEP L015)	mm	3377
Overall Chassis Length	(A / BEP L001)	mm	6311

HEIGHTS

Wheelbase		mm	3.900
Ground clearance, laden	Front (U1 / BEP H015)	mm	192
	Rear (U3 / BEP H016)	mm	215
Max. exterior height unladen	(BEP H001)	mm	3933
Max. exterior height, cab tilted, unladen	(O1 / BEP H061)	mm	4537.00
Cab height (unladen)	(O)	mm	3845
Distance from ground to lowest point at front of vehicle	Unladen (H0 / BEP H18)	mm	303.00
	Laden (H0 / BEP H18)	mm	297.00
Frame top height at front axle	Unladen (H1 / BEP H035)	mm	955.00
	Laden (H1 / BEP H036)	mm	946.00
Frame top height at drive axle	Unladen (H2 / BEP H037)	mm	972
	Laden (H2 / BEP H038)	mm	952
Frame top height at the rear of the frame	Unladen (HN)	mm	977.00
	Laden (HN)	mm	953.00
Centre of Gravity of vehicle	Unladen at Z (BEP H044)	mm	926.00
Side member height	(BEP H032)	mm	300.00

TOWING DEVICE

Wheelbase		mm	3.900
Distance between the front of the vehicle and the centre of the trailer coupling device	(BEP L073 + L016)	mm	4715.00
Distance between centre of last axle to centre of coupling device		mm	
Fifth wheel height, from top of side member	(BEP H074 + H071)	mm	270.00
Fifth wheel height from ground	Unladen (BEP H076)	mm	1240
	Laden (BEP H078)	mm	1221
Swept Swing Clearance	(BEP L078)	mm	
Fifth wheel position	Max. (Ymax / BEP L075)	mm	1100
Gross Vehicle Weight	at YMAX	Kg	23400.00
Gross Vehicle Weight, load on front axle(s)	at YMAX	Kg	8000.00
Gross Vehicle Weight, load on rear axle(s)	at YMAX	Kg	15400.00
King Pin Load	at YMAX	Kg	14169.00
King Pin Load on Front Axle(s)	at YMAX	Kg	2244.00
King Pin Load on RearAxle(s)	at YMAX	Kg	11925.00
Fifth wheel position	Min. (Ymin / BEP L077)	mm	550
Gross Vehicle Weight	at YMIN	Kg	23400.00
Gross Vehicle Weight, load on front axle(s)	at YMIN	Kg	4400.00



Gross Vehicle Weight, load on rear axle(s)	at YMIN	Kg	19000.00
King Pin Load	at YMIN	Kg	14169.00
King Pin Load on Front Axle(s)	at YMIN	Kg	-1356.00
King Pin Load on RearAxle(s)	at YMIN	Kg	15525.00
Fifth wheel position	Manufacturer's recommendation (Y / BEP L076)	mm	550
Gross Vehicle Weight	in fifth wheel position recommended by manufacturer	Kg	23009.00
Gross Vehicle Weight, load on front axle(s)	in fifth wheel position recommended by manufacturer	Kg	8000.00
Gross Vehicle Weight, load on rear axle(s)	in fifth wheel position recommended by manufacturer	Kg	15009.00
King Pin Load	in fifth wheel position recommended by manufacturer	Kg	13778.00
King Pin Load on Front Axle(s)	in fifth wheel position recommended by manufacturer	Kg	2244.00
King Pin Load on RearAxle(s)	in fifth wheel position recommended by manufacturer	Kg	11534.00
Fifth wheel position	Intermediate 1	mm	500.00
Gross Vehicle Weight	in intermediate fifth wheel position 1	Kg	23400.00
Gross Vehicle Weight, load on front axle(s)	in intermediate fifth wheel position 1	Kg	7854.00
Gross Vehicle Weight, load on rear axle(s)	in intermediate fifth wheel position 1	Kg	15546.00
King Pin Load	in intermediate fifth wheel position 1	Kg	14169.00
King Pin Load on Front Axle(s)	in intermediate fifth wheel position 1	Kg	2098.00
King Pin Load on RearAxle(s)	in intermediate fifth wheel position 1	Kg	12071.00
Fifth wheel position	Intermediate 2	mm	450.00
Gross Vehicle Weight	in intermediate fifth wheel position 2	Kg	23400.00
Gross Vehicle Weight, load on front axle(s)	in intermediate fifth wheel position 2	Kg	7644.00
Gross Vehicle Weight, load on rear axle(s)	in intermediate fifth wheel position 2	Kg	15756.00
King Pin Load	in intermediate fifth wheel position 2	Kg	14169.00
King Pin Load on Front Axle(s)	in intermediate fifth wheel position 2	Kg	1888.00
King Pin Load on RearAxle(s)	in intermediate fifth wheel position 2	Kg	12281.00
Sliding fifth wheel	front fork	mm	4.71
	rear yoke	mm	4.05

WIDTHS

Wheelbase		mm	3.900
Max exterior cab width with rear view mirrors open	(BEP W001)	mm	2926.00
Max. cab width	(BEP W002)	mm	2534
Frame width	Front (BEP W035)	mm	1080
	Rear (BEP W036)	mm	850
Width at rear wheels	Rear axle 1 (V3 / BEP W003.2)	mm	2490
	Rear axle 2 (V5 / BEP W003.3)	mm	2499
Track	Front (V1 / BEP W013.1)	mm	2109
	Rear 1 (V2 / BEP W013.2)	mm	2104
	Rear 2 (V4 / BEP W013.2)	mm	1837.00

OTHER

Wheelbase		mm	3.900
Approach angle	(BEP H010)	°	11
Ramp angle	(BEP H012)	°	20.80
Departure angle	(BEP H011)	°	17.70
Side member thickness	(BEP W034)	mm	7.00
Turning Radius	Overall (BEP W012)	mm	6900.00
	kerb to kerb	mm	6243.00
	interior	mm	2634.00

13 ENGINE

TURBOCOMPOUND ENGINE

Recovering heat that would otherwise be lost, the turbo compound converts exhaust energy into mechanical energy that is delivered to the crankshaft, increasing the engine's torque.

Maximum power: 360 kW from 1250 to 1600 rpm

Maximum torque: 2700 Nm from 900 rpm to 1250 rpm

Power Output (UK): 480 TC hp

6-cylinder in-line diesel engine - Common rail high-pressure fuel-injection (2000 bar) - 24 valves - overhead camshaft, rear-mounted timing

High pressure provided by three pumps on injector bodies.



Bore 131 mm - stroke 158 mm - Capacity 12.8 L
Electronically-controlled fan
Turbocharger
Direction of rotation (seen from gearbox end): anti-clockwise
Oil filter with additive
Oil service interval up to 100,000 km
EEC EURO VI pollution control level
Compact after-treatment system (catalytic converter, DPF, SCR)
Cooling liquid
Automatic regeneration of particulate filter
Noise standard R51.03

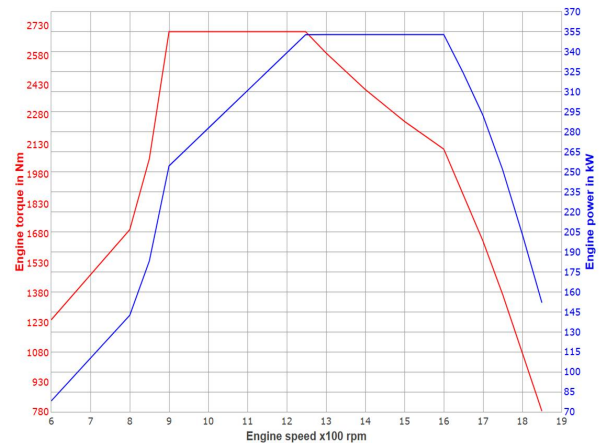

ENGINE EQUIPMENT

Power mode inhibited after passing the 'hard spot' of the accelerator pedal
Partial gas recycling (semi-closed circuit)
Automatic engine cut-off (5 min)
Without engine Power Take Off.
Electronic speed limiter (90 km/h).

CLUTCH

Single-plate clutch, diameter 430 mm

ELECTRONIC EQUIPMENT:

Multilingual display
SAE cab socket for vehicle data extraction
Load per axle indicator
FMS Gateway fleet management interface
Assistance button for geolocation via the 24/7 platform
4G TGW3 telematics unit (telematic gateway) including an antenna and enabling subscription to Optifleet services (Map, Check, Drive) - Auto activation.
TELENOR SIM card
Camera-based driver behaviour warning system (DAS-W2) and lane departure warning system (LDWS) with course correction.
Side radar for covering both sides of the truck
Forward Collision Warning System with Advanced Emergency Braking System (AEBS) and Adaptive Cruise Control (ACC)

GEARBOX

Optidriver AT 2812 gearbox (14.94 - 1) with automatic clutch.
Aluminium housing.
Max. torque 2800 Nm, 12 forward gears and 3 reverse gears.
Steering wheel-mounted operating mode selection (automatic/manual) via gear shift selector,
Optivision Map Based + Traffic Info gearshift strategy for FUEL ECO (advance warning of hills, bends and

roundabouts. Centralised data storage with traffic information).

Gearbox rear intermediate housing in aluminium
Gearbox oil cooler, oil/water heat exchanger

RETARDER

OPTIBRAKE+ (power rating 430 kW at 2300 rpm):
combination of the exhaust brake and valve compression braking, coupled to service brake

POWER TAKE-OFF

Without gearbox mounted PTO

STEERING

Right hand drive.
Hydraulic power steering, electronically controlled variable flow pump.
Steering ratio 23.2
Variable power steering
Driving on the left

FRONT AXLE

Maintenance-free axle with pivots
Front load capacity (technical max.): 8 t

REAR AXLE

Liftable rear axle
Load transfer to drive axle (10.5 t + 30% if speed below 30 km/h)
Rear axle position : in front of engine drive axle

BRAKING

Service brake:



870 l/min air compressor.
Braking system with two independent circuits.
Ventilated disc brakes.
Electronic management of air production by EACU (Electronic Air Control Unit):
Dryer cartridge optimised by preventive maintenance.
Steel protective cover on EACU
Disengageable air compressor
Aluminium air tanks.
Brake hose couplers, UK standard
Electrical lead with one 15-pin connector to two 7-pin connectors (24N, 24S)
Downward-facing semi-trailer connection
Dummy sockets for electrical cables on DFR
Trailer brake device at cab rear, in aluminium

EBS:

Anti-lock braking system (ABS).
Anti-slip regulation (ASR).
Brake balancing between tractor unit and trailer.
(Disc) brake pad wear compensation
Retarder and service brake linking
Differential engagement management (if equipped) at speeds <10 km/h (4x2)
Hill Start Assist
Braking performance warning
ESC (Electronic Stability Control) trajectory control and anti-rollover system
Coupling traction test
Emergency brake assist (EBA)
Stop lights emergency lighting

Parking brake:

EPB (Electronic Parking Brake) automatic parking brake, immobilization provided by spring cylinders
Automatic parking brake activated when the driver exits the vehicle with the ignition switched on.

WHEELS AND TYRES

Dimension 385/55 + 385/55 + 315/70 R22.5
TYRE: PROFILE
Continental EFFICIENT PRO HS5/HD5
Steel disc wheels
ISO_11992 compatible tyre pressure monitoring system
Steel front wheel trims
Without spare wheel.

REAR DRIVE AXLE

P13170-FR single-reduction rear axle. 13T axle load, 50T capacity with reinforced differential. Hypoid final drive
Integral differential lock
Rear loading capacity (technical max.): 19 t
Rear load 7.5t - 11.5t
Drive axle ratio: 2.31

CAB**Cab exterior:**

High Sleeper cab
All steel Cab, electro-zinc plated and cathaphoretic paint treatment.
Cab paint colour: Red metallic
technical code: 02771
Red badge
Aerodynamic dirt deflectors on the headlamps
4-point cab air suspension with ride-height control system
Electrically operated cab tilt.
Four side storage compartments of which one is accessible from inside the cab
Driver and passenger side rear-view cameras
No rear-view mirror. Rear view using a camera
Blind spot camera
Kerb view mirror.
Rear view mirrors for bodywork up to 2.55 m wide
Fold-back front view mirror
Twin air horns - roof mounted.
Laminated side windows.
Spray suppression on front wings
Fixed roof deflector
Side deflectors (2 opening panels)
Door extensions (step cover)
Exterior parts finished in cab colour
Wide external sun visor
Tinted, laminated windscreen.

Cab interior:

Black grab handles
Interior cab finish - Red
Performance roof console, 4 storage compartments with doors including 1 with key lock, 1 storage space with net, 4 ISO modules
Electric interior sun blind on windscreen, manual blinds on driver and passenger side windows
With digital camera.
TV aerial pre-equipment
DTCO 4.1 digital tachograph
Offset 24 V socket
No roof air vent
No mosquito screen on ventilator
Synthetic carpet floor mats
LUXURY DRIVER'S SEAT:
Adjustable vertical damping
Seat squab tilt
Length and height-adjustable
Removable cover
Adjustable headrest
Seat quick-drop function with height setting memory
Seat back side support adjustment
Seat cushion side support adjustment
Adjustable lumbar support
Extendible seat squab cushion
Heating system (driver's seat)
Ventilation (driver seat)
Seat with longitudinal suspension
Two driver's armrests
Red seat belts
Seat belt fastened reminder
Air suspension
Adjustable vertical damping
Neck support

Height-adjustable

Easy Access

Stowage on rear of seat back

2 arm rests

Two passenger armrests

Leather and fabric upholstery

Sérénité lower bunk: 2018mm long, 670mm wide (790mm between seats), mattress thickness: 170mm

Mattress topper (memory foam)

Removable back rest

Driver's airbag.

Blower

Air blower inside the cab

XL drawer + bottle holder (1.5 L bottle) + waste bin (3.2 L)

Cab interior lighting management rotary control

(Activity/Rest/Night driving), brightness adjustment

Reading lamps on overhead console

LED direct and indirect cab lighting

Red night lighting covering 3 rows on the overhead console

Cab lighting time-delay.

Curtains with solar insulation around the cab

Bunk area lighting

Remote control for comfort functions in bunk area with integrated display

12 V & 5 V socket (bunk)

40L refrigerator in central storage under bench, quiet with thermostat and vehicle battery management

2 storage boxes under bunk, one accessible from interior and exterior

Remote control for comfort functions in bunk area with integrated display

12 V & 5 V socket (bunk)

40L refrigerator in central storage under bench, quiet with thermostat and vehicle battery management

2 storage boxes under bunk, one accessible from interior and exterior

First-aid box

Driver's window with impulse control.

2kW stand-alone cab heater (air/air). Air distribution via three vents (behind the left seat, behind the right seat and above the bunk)

Reinforced heat insulation

Electronically regulated comfort air conditioning with compressor optimisation

Cab air filtration, washable filter

Dometic SPX1200 self-contained air-conditioning

Handbook and Service pack in English.

4 loudspeakers and 2 tweeters

Fire extinguisher 3kg

Steering wheel equipment:

Ultimate leather steering wheel with red stitching

OPTIDRIVER control

OPTIBRAKE and retarder control on right-hand side

3-way adjustable steering column

Writing clipboard

Multifunction screen with DAB radio

Instrument panel:

COMPACT dashboard

12" HD colour information display

Speedometer in miles

12 V + 24 V socket on dashboard, for accessories.

Starting inhibitor controlled by transponder key.

Ready to fit alcohol ignition interlock device

Start button

3rd ignition key

Customer adjustable overspeed downhill

ECO cruise control with Optiroll and Smart Torque.

Intelligent speed assistance. Intelligent Speed Assist: speed limit sign recognition, in-cab display and overtaking warning. Power mode inhibited after passing the 'hard spot' of the accelerator pedal
Without Eco Off switch

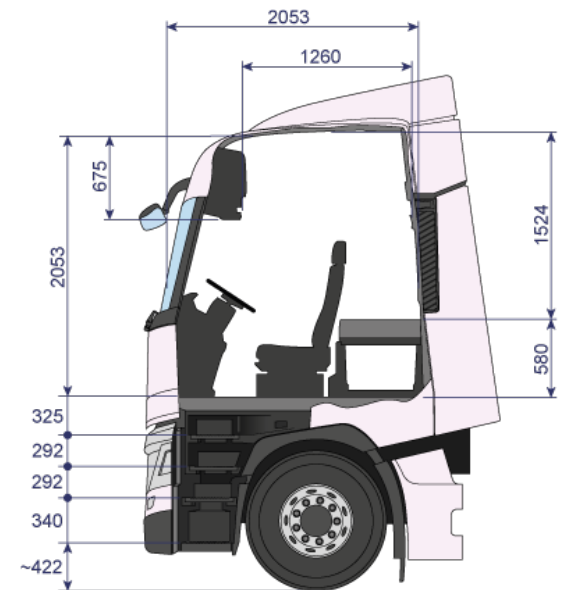
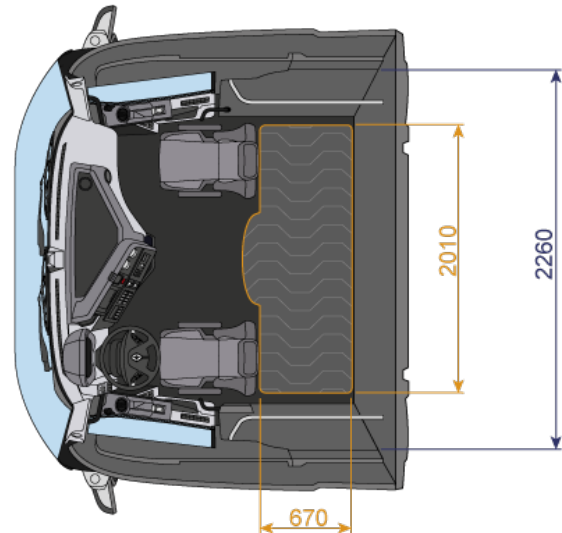

ELECTRICAL EQUIPMENT

Batteries located in the rear overhang
210 Ah AGM batteries
Maintenance-free batteries
Battery cut-out remote control
Electrical circuit automatically goes to standby
Battery charge indicator



No protection on rear lights
LED rear signalling and lighting (EEC standard e2 10113)

CHASSIS

Chassis protective paintwork, mineral grey colour
technical code: 03650
Removable front towing cap.
Front under-run protection.
Transmission crossmember Reinforced
Closing cross member with pre-drilling for towing yoke
Pneumatic sliding medium fifth wheel mounting H=50 mm
Jost JSK 36D (sheet metal), 2" sheet metal fifth wheel, D 152 kN
Fifth wheel position: Y = 550 mm
Reinforced chassis guard rail
Extended rear platform.
Extension de passage de roue
Compact road air filtration
Rear wings with anti-spray
Wings fitted in standard position.
Side exhaust.

BUMPER - STEPS AND LIGHTING

Plastic bumper with integral spoiler
Retractable windscreen access step in radiator grille
Access to driving position by 4 steps
Step lighting.
Metallic door sills
BUMPER CORNERS, CENTER, AND STEPS PAINTED IN CAB COLOR
Automatic windscreen wiping with rain sensor
Automatic lights according to luminosity
and automatic selection of main or dipped beam headlights
LED day running lights
Provision for lighting rail on roof
White LED work light (850 lm)
Front fog lights.
Fixed Bending Lights
LED headlights comprising 2 modules of 5 cells:
- 1 module with three cells for main beam (1450 lumen)
- 1 module with two cells for dipped beam (700 lumen)
Indicators and daytime running lights are managed by a high brightness two-tone LED strip light
Roof beacon pre-equipment
Integrated headlamp washer

SUSPENSION

Front suspension

GEARBOX RATIOS

1	2	3	4	5	6	7	8	9	10	11	12
14.94	11.73	9.04	7.09	5.54	4.35	3.44	2.70	2.08	1.63	1.27	1.00

The manufacturer reserves the right to modify the specifications above without prior notice.
Non contractual document.

For further assistance please contact Product Applications at Renault Trucks UK Limited, Wedgnoek Lane , Warwick , CV34 5YA Telephone +44 (0)1926 475333.

2-leaf front leaf springs
Front anti-roll bar.

Rear suspension:

Air suspension
Rear stabiliser bar.
Suspension remote control (2 channels).

FUEL TANK

Main aluminium tank
Main fuel tank: 480 litres capacity D710 profile mounted on left & with access steps
Anti-siphoning device
Heavy duty sedimenter and prefilter (R90).Bleed control on dashboard.

AdBlue

64-litre AdBlue tank.
"D" profile, 710 mm diameter.
Urea tank on the right

STANDARD EQUIPMENT

Tool kit.
Warning triangle.
Reversing warning buzzer, including night switch.

BODYWORK

Bodybuilder access through bulkhead
2 adjustable lamps mounted on the top of the rear of the cab.
Orange LED side marker lights with reflector
Interface for bodybuilder connections and BBM module (Body Builder Module)
Bodybuilder electrical interface on chassis

SERVICE

Optifleet:

Optifleet Check: technical data reports for fuel consumption monitoring by vehicle and by driver, 1-year prepaid subscription
Optifleet Map: vehicle geolocation, geofencing and route analysis, 1-year prepaid subscription
Optifleet Safety Service: monitoring driver behaviour and recording safety events. 1 year subscription
SYGIC NAVIGATION connected app +
With dynamic maintenance plan.



